



Single-phase Hybrid Inverter

USER MANUAL

HIS-3L-G3
HIS-3.6L-G3
HIS-4.6L-G3
HIS-5L-G3
HIS-6L-G3

Legal Notice

Hoymiles has made every effort to ensure the accuracy and completeness of this manual. However, this manual may be changed and revised due to product enhancements or user feedback.

Hoymiles reserves the right to modify this manual without prior notice at any given time. The latest version of this manual can be found by visiting the Hoymiles official website www.hoymiles.com or scanning the QR Code below.



Warranty

Follow the installation instructions in this manual to ensure warranty compliance and reliability. The current warranty conditions can be accessed at www.hoymiles.com.

Contact Information

If you have technical queries or any questions concerning our products, please contact our support through the Hoymiles service portal:



Germany
service.de@hoymiles.com

Italy
service.it@hoymiles.com

Poland
service.pl@hoymiles.com

Other EU countries
service.eu@hoymiles.com

Spain
service.es@hoymiles.com

Netherlands
service.nl@hoymiles.com

Finland
service.fi@hoymiles.com

Australia & New Zealand
service.au@hoymiles.com

France
service.fr@hoymiles.com

Norway
service.no@hoymiles.com

Austria
service.at@hoymiles.com

Asia & Pacific
service.asia@hoymiles.com



Germany
+49 6994322186

Poland
+48 918821656

France
+33 159131589

Netherlands
+31 852736388



hoymiles.com

Revision History

Version	Date	Description
REV1.1	-	Official Release
REV1.2	20260113	Updated the recommended cable sizes for the Gound, Battery and COM2 connections.
REV1.3	20260318	Updated the technical data. See Page 64 .

Contents

1	About This Manual	1
1.1	Purpose	1
1.2	Audience	1
1.3	Validity	1
2	Safety Information	2
2.1	Safety Symbols	2
2.2	Additional Symbols	2
2.3	Safety Instructions	3
2.4	EU Declaration of Conformity	4
3	Transportation and Storage	5
3.1	Transportation Requirements	5
3.2	Storage Requirements	5
4	Product Introduction	6
4.1	Product Appearance	6
4.2	LED Indicators	7
4.3	Supported Power Grid	8
4.4	Working Modes	8
4.4.1	Self-consumption Mode	8
4.4.2	Economy Mode	9
4.4.3	Backup Mode	10
4.4.4	Peak Shaving Mode	11
4.4.5	Time of Use Mode	12
4.4.6	Off-grid Mode	12
5	System Overview	13
6	Installation Instructions	14
6.1	Unpacking	14
6.2	Environmental Requirements	14
6.3	Space Requirements	15
6.4	Installation Tools	17
6.5	Installation Steps	18
7	Electrical Connection	20
7.1	Wiring Diagram	20
7.2	Recommended Cable List	22
7.3	Internal Overview	23
7.4	Ground Cable Connection	23
7.5	PV Cable Connection	24
7.6	Battery Cable Connection	25
7.7	AC Cable Connection	26
7.7.1	Grid Connection	27
7.7.2	EPS Connection	28
7.7.3	GEN Connection	29

7.8	Communication Cable Connection (COM1).....	30
7.8.1	Parallel Connection.....	31
7.8.2	Smart Meter and CT Connection	32
7.8.3	BMS Connection.....	34
7.8.4	DRM Connection.....	35
7.9	Communication Cable Connection (COM2).....	37
7.10	Installing the Wiring Box Cover.....	38
7.11	Installing the DTS	39
8	System Commissioning.....	41
8.1	Preparation	41
8.2	System Power-on.....	41
9	S-Miles Cloud.....	42
9.1	Connect to the DTS.....	42
9.2	Start Commissioning.....	44
9.3	Perform System Settings.....	49
9.3.1	Set Advanced Parameters	49
9.3.2	Enable DRM Function.....	52
9.3.3	Set Export Management Parameters.....	53
9.3.4	Set Working Mode.....	54
9.3.5	Set Dry Contact Function.....	55
9.4	Upgrade the Firmware.....	58
10	System Maintenance	59
10.1	System Power-off.....	59
10.2	Routine Maintenance	59
10.3	Troubleshooting	60
11	Decommissioning	63
11.1	Removing the Product	63
11.2	Packing the Product.....	63
11.3	Disposing of the Product	63
12	Technical Datasheet.....	64
13	Appendix 1: Application of an AC Coupled System	65
14	Appendix 2: Application of Parallel Function	68
15	Appendix 3: Application of Lead-acid Battery	74
16	Appendix 4: Application of Generator	76
17	Appendix 5: Application of EV Charger	80
18	Appendix 6: Application of Heat Pump	82

1 About This Manual

1.1 Purpose

This manual provides information on the installation, electrical connections, operation, and maintenance of the HIS-(3-6)L-G3 series.

Please consider the following before installation:

- Carefully read this manual before operation.
- Keep this manual for reference.

1.2 Audience

This manual is intended for use by qualified persons only. Qualified persons must have the following skills:

- Knowledge of how an inverter works.
- Knowledge of how a battery works.
- Training in how to deal with the dangers and risks associated with the installation, maintenance, and use of electrical devices.
- Training in the installation, commissioning, and maintenance of electrical devices.
- Knowledge of and compliance with all applicable laws, standards, and directives.

1.3 Validity

This manual is valid for:

- HIS-3L-G3
- HIS-3.6L-G3
- HIS-4.6L-G3
- HIS-5L-G3
- HIS-6L-G3

NOTE

Model identifier:

HIS - 3L - G3
T TT T
A BC D

[A]: Series Name (Single-phase Hybrid Inverter)

[B]: Output Power (3 kW)

[C]: Compatible with Low Voltage Battery





[D]: Generation (The Third Generation)

2 Safety Information

Before installing, operating, commissioning, and maintaining the equipment, please carefully read the safety rules and usage instructions in this document as failure to do so may result in safety hazards or device damage. Safety instructions in this manual cannot cover all precautions that should be taken. Please consider the actual conditions on site when performing operations. Any damage caused by a violation of the safety instructions in this manual shall not be the responsibility of Hoymiles.



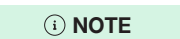

2.1 Safety Symbols



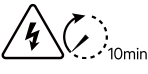

Safety symbols are used in this manual as follows:

Symbol	Description
 DANGER	This symbol indicates potential risks that, if not avoided, may lead to death or serious physical injury.
 WARNING	This symbol indicates potential risks that, if not avoided, may lead to personal injury or device damage.
 CAUTION	This symbol indicates potential risks that, if not avoided, may lead to device malfunctions or financial losses.
 NOTICE	This symbol indicates potential risks that, if not avoided, may lead to minor injury or damage to the equipment.
 NOTE	This symbol indicates an important step or tip that leads to the best results but is not safety- or damage-related.

2.2 Additional Symbols

The product label contains the following symbols with their meanings described below:

Symbol	Usage
	Caution Failure to observe any warnings contained in this manual may result in injury.
	Danger to life due to high voltages Only qualified personnel can open and maintain the equipment.
	Hot surface Burn danger due to hot surface that may exceed 60°C.
	After the equipment is turned off, wait for at least 10 minutes before opening the equipment or touching live parts.
	Treatment Electrical equipment that has reached the end of life must be collected separately and returned to an approved recycling facility to comply with the European Directive 2002/96/EC on Waste Electrical and Electronic Equipment and its implementation as national law. Return any devices you no longer need to an authorized dealer or an approved collection and recycling facility.

	CE mark The product complies with the requirements of the applicable EU directives.
	UKCA mark
RoHS	RoHS mark
	Ukrainian certification mark
	Observe the documentation Read and understand all documentation supplied with the product.

2.3 Safety Instructions

To prevent personal injury and property damage and to ensure the long-term operation of the product, read this section carefully and observe all safety information at all times. Failure to observe the prescribed instructions may potentially void the manufacturer's warranty. If in doubt, please contact Hoymiles.

DANGER

Danger to life from electric shock

- Only qualified personnel are allowed to install, maintain, or replace the device.
- Qualified personnel must wear personal protective equipment (PPE) during operation.
- Attempting to service the device yourself may result in a risk of electric shock or fire and will void your warranty.
- Never insert or remove the AC connections when the device is running.
- The installation location must be inaccessible to children.
- The device should be installed away from heating devices.
- Before installation, operation, and maintenance, ensure that the upstream and downstream switches are disconnected.
- Before performing any work on the device, disconnect all power supply and wait for at least 10 minutes. The hazardous voltage will exist for up to 10 minutes after disconnection from the power supply.

WARNING

Risk of burns from hot surfaces

- The surface of the device might exceed 60°C, and touching the surface may result in burns.
- Do not touch hot surfaces before it cools down.
- All powers should be disconnected from the device before attempting any maintenance, cleaning, or working on any circuits connected to the device.
- Keep away from flammable and explosive materials to avoid fire hazard.
- The device should be installed away from humid or corrosive substances.
- When accessing the internal circuit of the device, wait for at least 10 minutes after disconnecting the power.

⚠ CAUTION

- Ensure that the existing wiring is in good condition and no wire is undersized.
- Do not disassemble any parts of the device which are not mentioned in the installation.
- Authorized service personnel must use insulated tools when installing or working with this device.

NOTICE

- The minimum rated temperature of the wire used is 90°C (194°F).
- All electrical connections must be in accordance with local and national standards.
- Only with permission of the local utility grid company, the device can be connected to the utility grid.
- Do not open the inverter device or change any components without authorization, otherwise the warranty commitment for the device will be invalid.
- Prior to the application, please read this section carefully to ensure the correct and safe application. Please keep the user manual properly.
- The manual contains no instructions for user-serviceable parts. See Warranty for instructions on obtaining service.
- If an error occurs, contact your local distributor or qualified electricians.

2.4 EU Declaration of Conformity

Hoymiles Power Electronics Inc. hereby declares that the product described in this document is in compliance with the basic requirements and other relevant provisions of the following directives.

- Electromagnetic Compatibility Directive 2014/30/EU (EMC)
- Low Voltage Directive 2014/35/EU (LVD)
- Restriction of the use of certain hazardous substances Directive 2011/65/EU and its amendment directives (EU) 2015/863 (RoHS)
- Waste Electrical and Electronic Equipment Directive 2012/19/EU (WEEE)

More detailed information can be found at <https://www.hoymiles.com>.

3 Transportation and Storage

3.1 Transportation Requirements

Placement Requirements

- Place the inverter in the original packaging or specially designed transport packaging. The packaging materials should have sufficient strength and cushioning performance to prevent damage caused by collisions and squeezes during transportation.
- Secure the inverter firmly inside the packaging to avoid displacement during transportation. For large or heavy products, additional fixing devices may be required.
- Maintain stability and avoid sudden starts, stops, or excessive vibration during transportation.

Personnel Requirements

- Observe the safety symbols on the package of the inverter before transportation.
- Pay attention to the weight of the inverter. Be cautious to avoid injury when moving. Handle the inverter according to the personnel quantity required by local regulations.
- Wear protective gloves and use professional handling equipment to prevent injuries.
- Hold the handle position and the bottom position of the inverter when lifting it. Keep the inverter horizontal in case it falls.
- Ensure that only qualified and experienced personnel perform relevant operations.

3.2 Storage Requirements

Placement Requirements

- Keep the inverter in its original packaging with desiccants retained until it is ready for installation.
- To avoid personal injury or device damage, stack inverters carefully to prevent them from falling.
- Do not tilt or invert the package.
- Do not place heavy objects on the inverter, as this may damage the equipment housing or internal components.

Environmental Requirements

- The storage temperature should be between -40°C and 70°C , and the relative humidity should be between 5% and 95%, without condensing.
- Store the inverter in a clean and dry place to protect it from dust and moisture.
- Store the inverter in a well-ventilated place to ensure proper air circulation and prevent equipment overheating.
- Do not store the inverter in places exposed to direct sunlight, wet by rain, or with strong electric fields.
- Do not store the inverter in places with chemically corrosive substances or where there are pests and rodents.

Routine Maintenance

- During the storage period, the inverter should be checked regularly, and it is recommended to check the inverter once every three months. Replace the packing materials damaged by insects or rodents in a timely manner.
- If the inverter has been stored for two years or longer, it must be inspected and tested by professionals before being put into use.

4 Product Introduction

The HIS-(3-6)L-G3 series is a high-performance single-phase hybrid inverter with excellent reliability. The intelligent EMS function supports Self-consumption Mode, Economy Mode, Backup Mode, off-grid mode, Peak Shaving Mode, and Time of Use Mode for multi-scenario applications. Monitoring management through S-Miles Cloud allows users to remotely diagnose and track the system performance over time, offering superior energy production.

4.1 Product Appearance

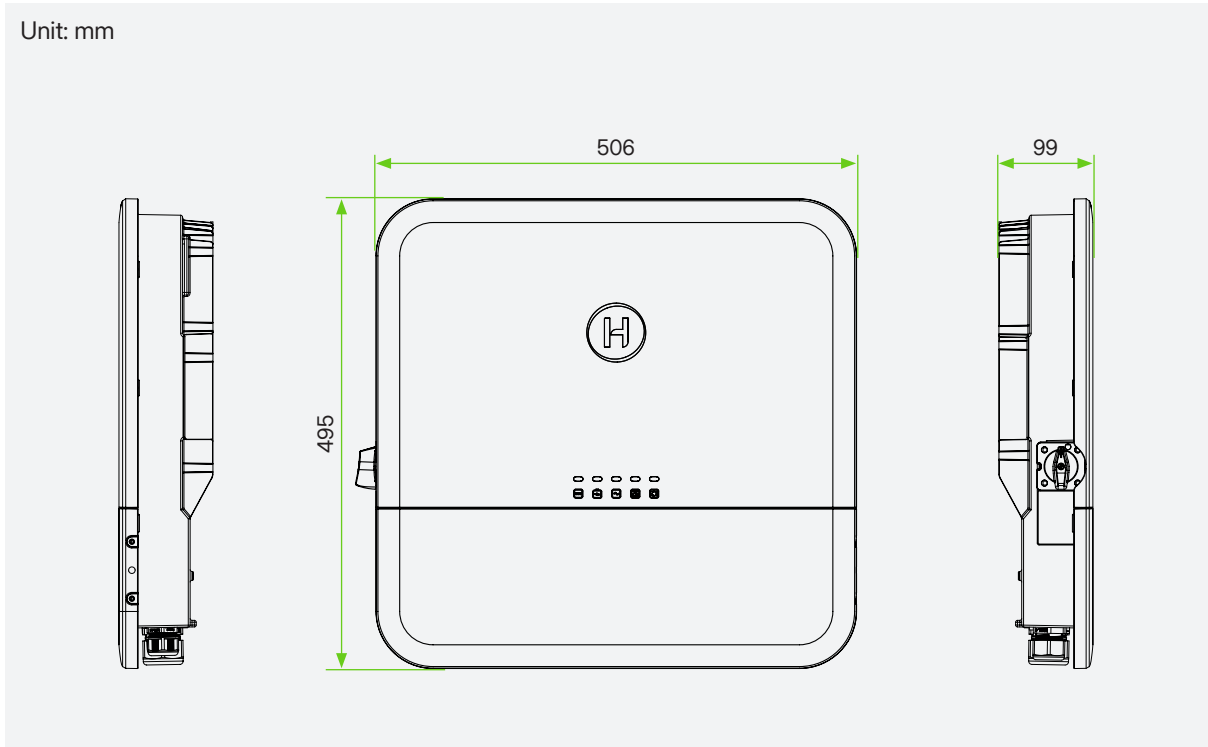

Figure 4-1 Appearance and Dimensions

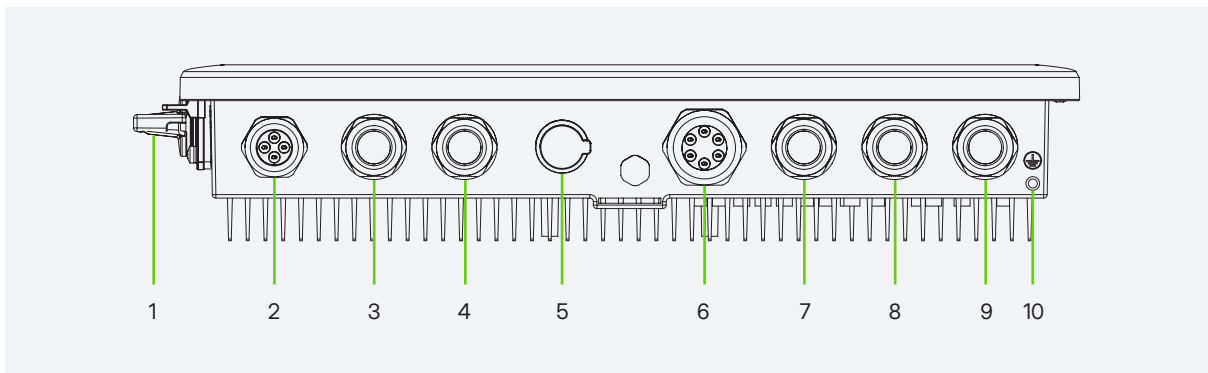

Figure 4-2 Bottom Overview

No.	Description	No.	Description
1	DC Switch	6	Communication Cable Entry
2	PV Cable Entry	7	GEN Cable Entry
3	Battery Cable Entry (BAT+)	8	EPS Cable Entry
4	Battery Cable Entry (BAT-)	9	Grid Cable Entry
5	Data Transfer Stick (DTS) Port	10	Ground Terminal

4.2 LED Indicators

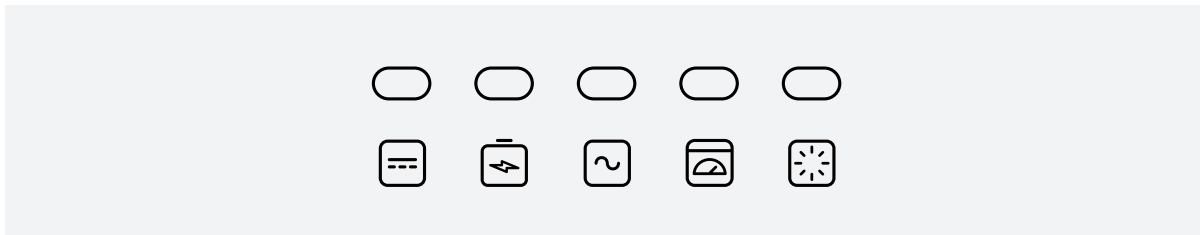























Figure 4-3 LED Indicators

Indicator		Status		Explanation
	PV		Solid blue	Normal
			Off	No PV Power
	Battery		Solid blue	Battery Discharging
			Flashing blue	Battery Charging
			Solid red	Battery Fault
			Off	No BMS Communication
	AC		Solid blue	On-grid Mode
			Flashing blue	Off-grid Mode
			Solid red	Grid Fault
			Off	No Grid Connection
	Meter		Solid blue	Normal
			Solid red	Communication Fault
			Off	No Meter Connection
	State		Solid blue	Normal System Operation
			Solid red	System Fault
			Off	Power Off

NOTE

When all five indicators flash blue, the inverter is being upgraded.

4.3 Supported Power Grid

There are different ways of wiring for different grid systems. TN-S/TN-C/TN-C-S/TT are shown as follows.

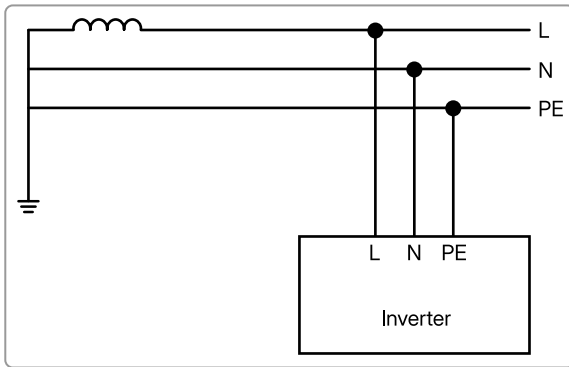

Figure 4-4 TN-S

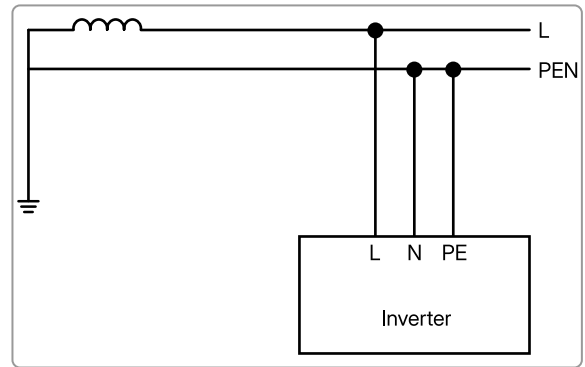

Figure 4-5 TN-C

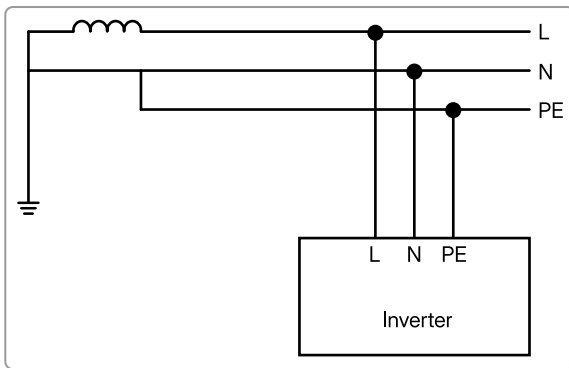

Figure 4-6 TN-C-S

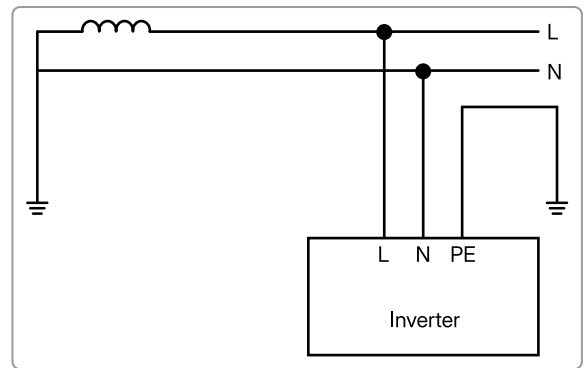

Figure 4-7 TT

4.4 Working Modes

The inverter has five working modes for you to choose in on-grid status, such as Self-consumption Mode, Economy Mode, Backup Mode, Peak Shaving Mode, and Time of Use Mode. You can choose the working modes according to your lifestyle and environment. When the system is not connected to the grid, you can choose the Off-grid Mode.

4.4.1 Self-consumption Mode

The Self-consumption Mode is the basic working mode, which can reduce the use of grid power.

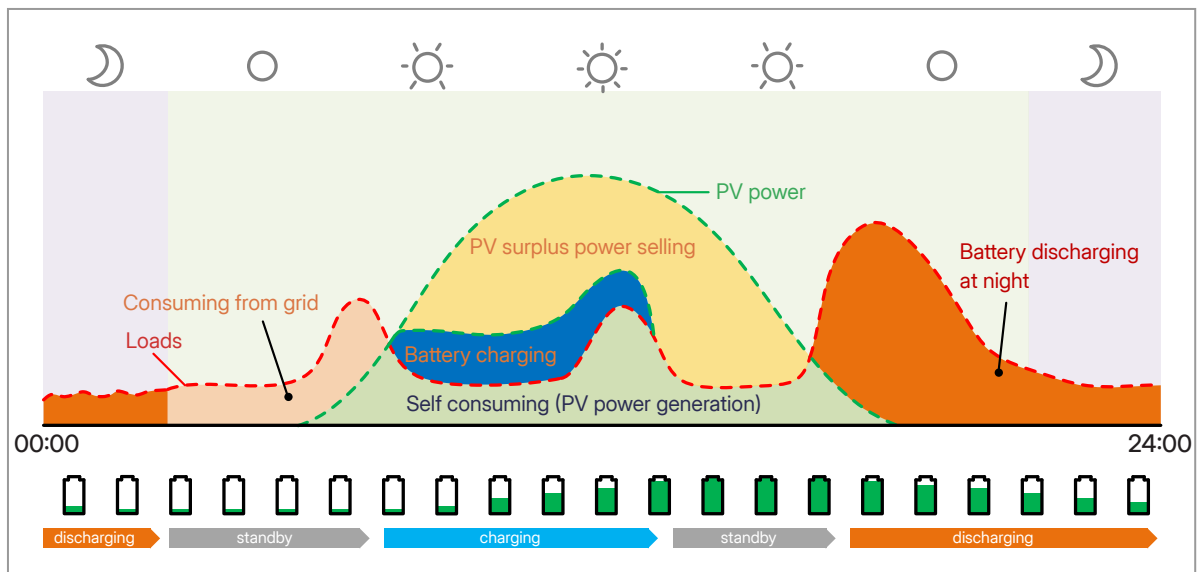

Figure 4-8 Power Flow of Self-consumption Mode

Time Period	Inverter Working Status
PV power is sufficient	$(PV \rightarrow \text{Loads}) > (PV \rightarrow \text{Battery}) > (PV \rightarrow \text{Grid})$ The power generated from PV first supplies the loads, and any excess power can charge the battery, and if there is still surplus power, it can be sold to the grid (or limited if necessary).
PV power is insufficient	$PV + \text{Battery} + \text{Grid} \rightarrow \text{Loads}$ The battery discharges power to the loads, and once its capacity reaches its reserved capacity, it automatically stops discharging, and the grid supplies power to the loads.

NOTE

- In order to maximize self-consumption, the grid will not charge the battery in this mode, and only the surplus PV power can charge the battery. The grid will initiate the charging process only when the battery SOC falls below the reserved capacity.
- Reserved SOC (10%-100%): The minimum battery SOC that can be reserved due to infrequent power outages. For details, refer to battery specifications.

4.4.2 Economy Mode

The Economy Mode can maximize electricity savings by shifting the battery state to avoid using grid electricity at peak hours. In this mode, the battery can be charged or discharged according to valley or peak electricity prices time. The system will calculate the savings based on the set currency.

Time Period	Inverter Working Status
Peak Hour	$(PV + \text{Battery} \rightarrow \text{Loads}) > (PV + \text{Battery} \rightarrow \text{Grid})$ The power generated from PV and battery can simultaneously supply the loads. Any excess power is then sold to the grid (or limited if necessary). The grid power will not be used until there is no PV power or the battery SOC reaches the reserved capacity.
Off-peak Hour	$PV + \text{Grid} \rightarrow \text{Loads} + \text{Battery}$ The power from PV and grid can simultaneously supply the loads and charge the battery.
Partial-peak Hour	Its working logic is the same as " Self-consumption Mode ".

NOTE

- Reserved SOC (10%-100%): The minimum battery SOC that can be reserved due to infrequent power outages. For details, refer to battery specifications.
- Time Setting:
 - Period (1-4): Set the start and end dates of the electricity rate period.
 - Time Range (2): Set time period in one week.
 - Peak Hour: Set peak electricity price time and trade price.
 - Off-peak Hour: Set off-peak electricity price time and trade price.
 - Partial-peak Hour: Set partial-peak trade price.

4.4.3 Backup Mode

The Backup Mode is suitable for areas with frequent power outages. This mode will maintain the battery capacity at a relatively high level to ensure that the EPS loads can be used when the grid is off.

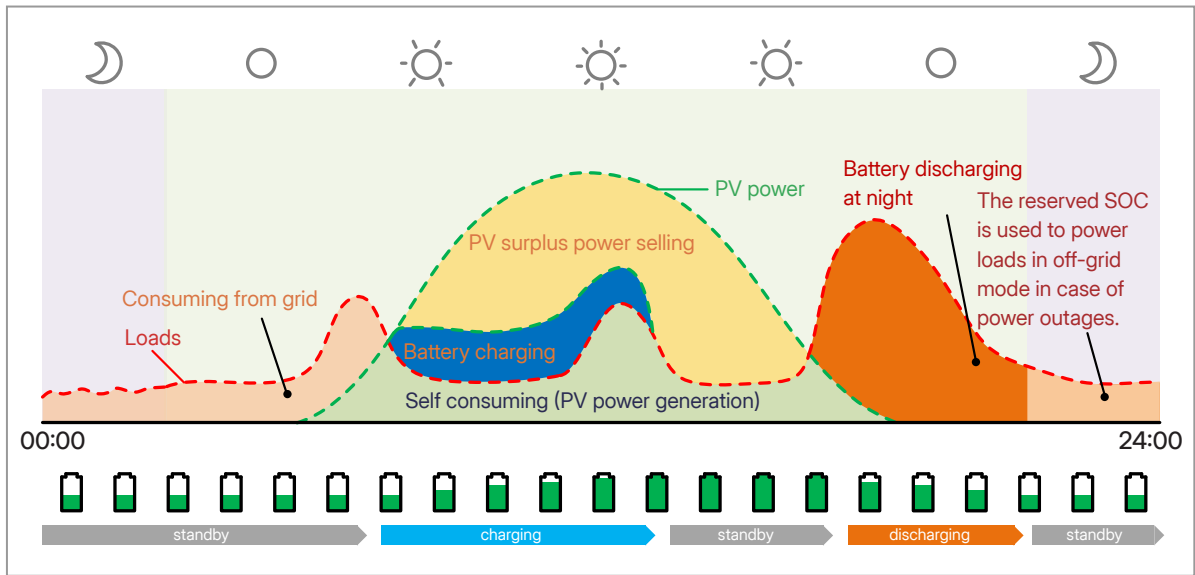

Figure 4-9 Power Flow of Backup Mode

Time Period	Inverter Working Status
PV power is sufficient	$(PV \rightarrow \text{Loads}) > (PV \rightarrow \text{Battery}) > (PV \rightarrow \text{Grid})$ The power generated from PV first supplies the loads. Any excess power can charge the battery, and if there is still surplus power, it can be sold to the grid (or limited if necessary).
PV power is insufficient	Battery SOC > Reserved Capacity $(PV + \text{Battery}) \rightarrow \text{Loads}$ The battery discharges power to the loads, and when its SOC reaches reserved capacity, it automatically stops discharging.
	Battery SOC \leq Reserved Capacity $(PV + \text{Grid}) \rightarrow \text{Loads}$ The grid supplies power to the loads. The battery does not discharge until the grid outage occurs. The battery needs to be recharged to the reserved capacity after the grid is normal.

NOTE

Reserved SOC (60%-100%): The minimum battery SOC that can be reserved due to infrequent power outages. For details, refer to battery specifications.

4.4.4 Peak Shaving Mode

The Peak Shaving Mode is used to level out peak power in electricity use to maximize electricity savings. In this mode, the Peak Meter Power (the maximum power that the inverter obtains from the grid) can be set; only when PV and battery can fully power the loads, can the Peak Meter Power be limited.

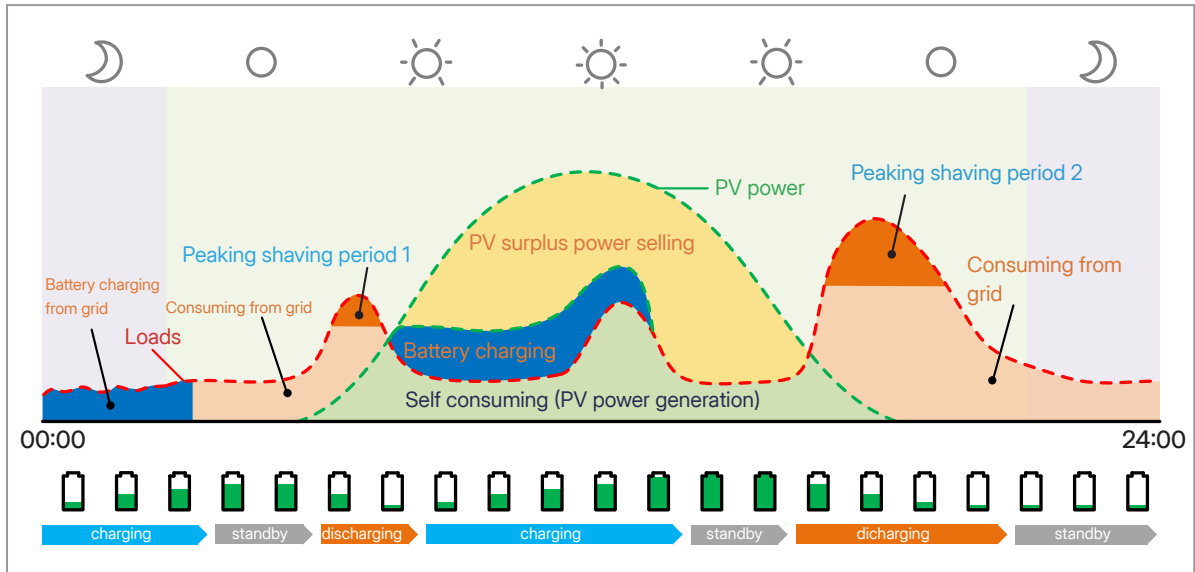

Figure 4-10 Power Flow of Peaking Shaving Mode

Time Period	Inverter Working Status
Grid Consumption Power > Peak Meter Power	PV + Battery → Loads The power generated from PV and battery can simultaneously supply the loads. The grid power will not be used until there is no PV power or the battery SOC reaches the reserved capacity.
Grid Consumption Power < Peak Meter Power	Battery SOC > Peak Capacity Its working logic is the same as " Self-consumption Mode ".
	Battery SOC ≤ Peak Capacity (PV + Grid → Loads) The grid can supply loads and charge the battery at a power not higher than the peak meter power.

NOTE

- Reserved SOC (10%-100%): The minimum battery SOC that can be reserved due to infrequent power outages. For details, refer to battery specifications.
- Baseline SOC (10%-100%): The minimum battery SOC that can be reserved during peak meter power time.
- Peak meter power (0-60000 W): The maximum load consumption power from the grid side.

4.4.5 Time of Use Mode

The Time of Use Mode allows users to customize the charging and discharging time of the battery within eight periods. Users can set the charging and discharging time according to the local peak and valley electricity price to save costs.

Time Period	Inverter Working Status
Charging Period	The battery will be charged from the grid at the pre-set charging power until the battery is charged to the pre-set stop charging SOC (%).
Discharging Period	The battery will discharge power to the loads and the grid at the pre-set discharging power until the battery discharges to the pre-set stop discharging SOC (%).
Other Period	Its working logic is the same as "Self-consumption Mode".

NOTE

- Reserved SOC (10%-100%): The minimum battery SOC that can be reserved due to infrequent power outages. For details, refer to battery specifications.
- Time period (1-8):

Charge Time	The battery can be charged at valley electricity price time.
Charge Power (0-100%)	The battery can be charged at this power.
Stop Charge SOC (0-100%)	The battery will stop charging when the battery SOC reaches this value.
Discharge Time	The battery can discharge at peak electricity price time.
Discharge Power (0-100%)	The battery can discharge at this power.
Stop Discharge SOC (0-100%)	The battery will stop discharging when the battery SOC reaches this value.

4.4.6 Off-grid Mode

The Off-grid Mode is used when the system is not connected to the grid.

5 System Overview

The HIS-(3-6)L-G3 series inverter can be connected to a battery and PV panels to form a PV Energy Storage System (ESS). In the event of a grid outage, it can be used as an emergency power supply (EPS) through the self-consumption of solar energy. The whole system has a rich application scenario, which not only supports the deep integration of PV, ESS, and EV Charger, but also supports heat pump and smart load control. To retrofit existing installations, users can also install a PV inverter to form an AC coupled system.

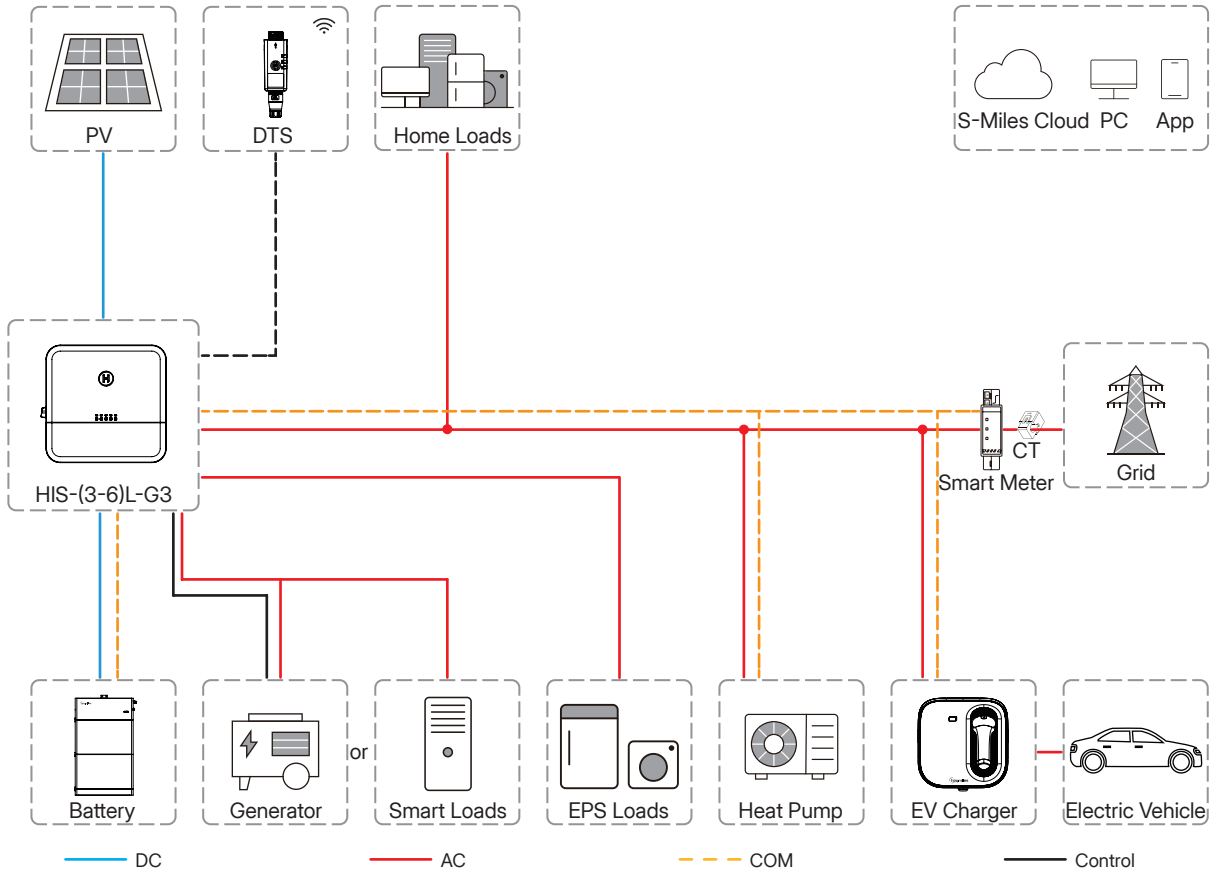

Figure 5-1 Basic System

6 Installation Instructions

⚠ DANGER

Danger to life due to fire or explosion!

- Despite careful construction, electrical devices can cause fires. This can result in death or serious injury.
- Do not install the product in places containing highly flammable materials or gases.
- Do not install the product in places where there is a risk of explosion.

⚠ WARNING

- Make sure there is no electrical connection before installation.
- To avoid electric shock or other injuries, make sure that holes are not drilled into any electrical parts or plumbing installations.
- Qualified personnel must wear personal protective equipment (PPE) during operation.

6.1 Unpacking

Unpack the package and carefully take out the product and other accessories. Check if the deliverables are complete and intact after unpacking the product. Please contact your supplier if the components are missing or damaged upon receipt of the product.

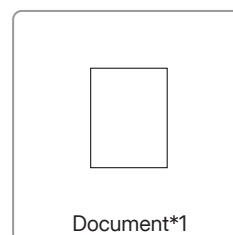
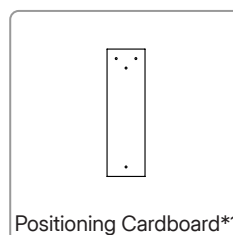
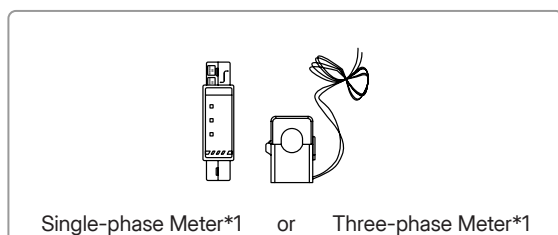
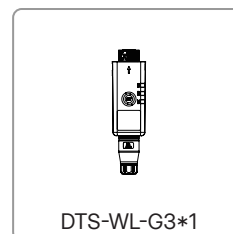
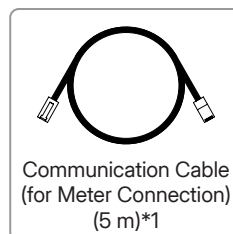
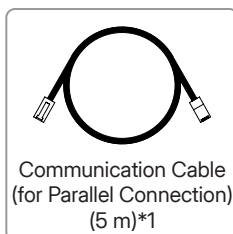
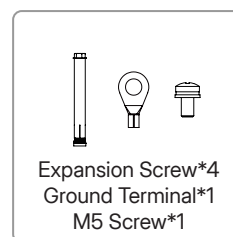
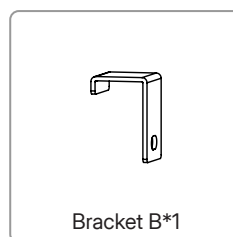
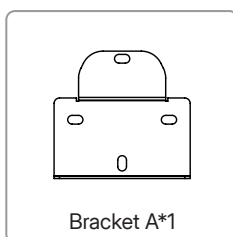
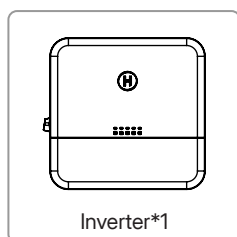

6.2 Environmental Requirements

- The inverter is designed with a protection degree of IP66 and can be installed indoors or outdoors.
- The inverter should be installed in a place where it can be protected from direct sunlight or bad weather such as snow, rain, or lightning.
- The ambient temperature should be between -25°C and 65°C . High ambient temperatures (above 45°C) will cause power derating of the inverter.
- The relative humidity should be less than 95%, without condensing.
- The inverter should be installed on a solid surface that is suitable for its dimensions and weight.
- The inverter should be installed in an environment with good ventilation and heat dissipation conditions.

- The inverter should be installed far from noise-sensitive areas.
- The inverter should be installed far from flammable materials, corrosive chemicals, and heating devices.
- The inverter should be installed in a place where its enclosure and heat sink are not easy to be touched, because these parts are hot during operation.

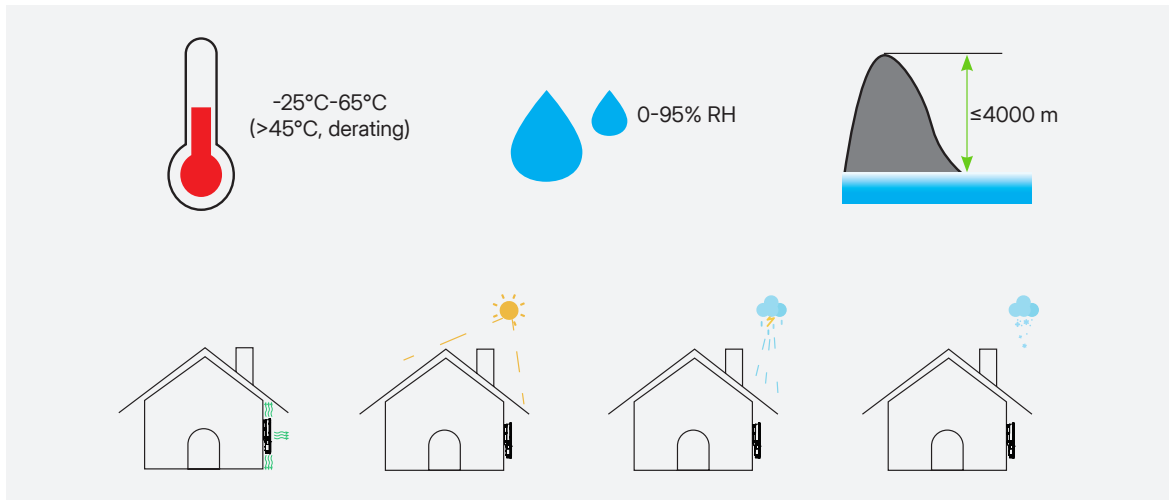

Figure 6-1 Installation Environment

6.3 Space Requirements

- Leave enough space around the inverter to ensure correct installation and heat dissipation.
- The inverter should be installed vertically or at a maximum back tilt of 15° and should not be installed forward-tilted, excessively backward-tilted, side-tilted, or horizontally.
- The inverter should be installed at eye level for convenient maintenance, and make sure the product label on the inverter remains visible after installation.
- For installation of multiple inverters, leave a minimum space of 500 mm between inverters. In areas with high ambient temperature, increase the space among inverters and provide good ventilation conditions if feasible.

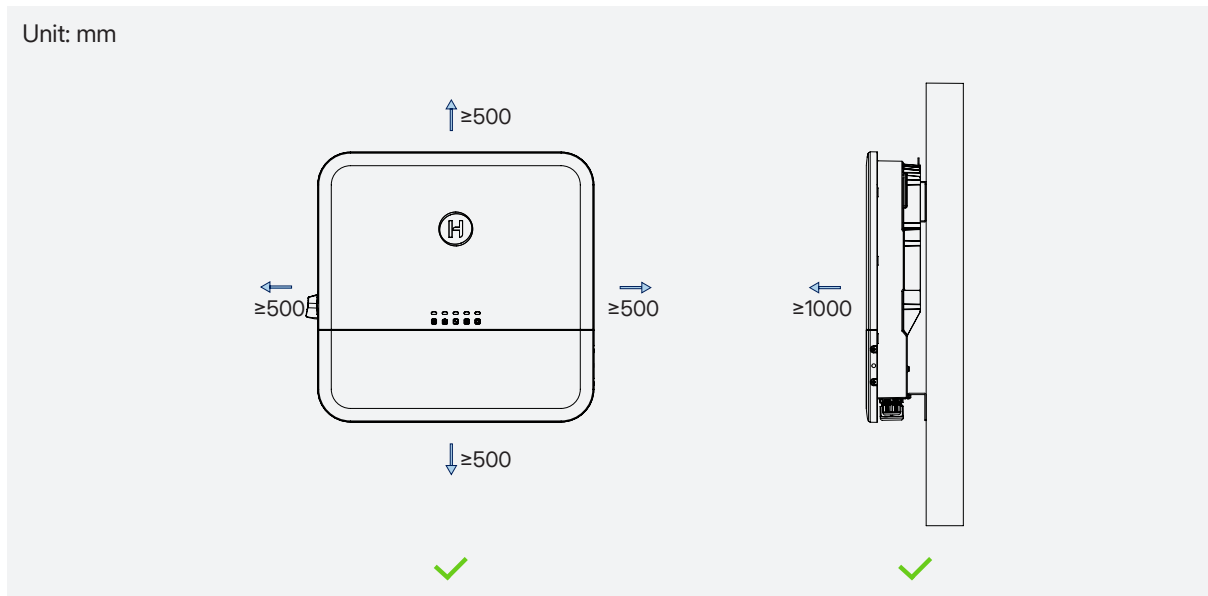

Figure 6-2 Correct Installation

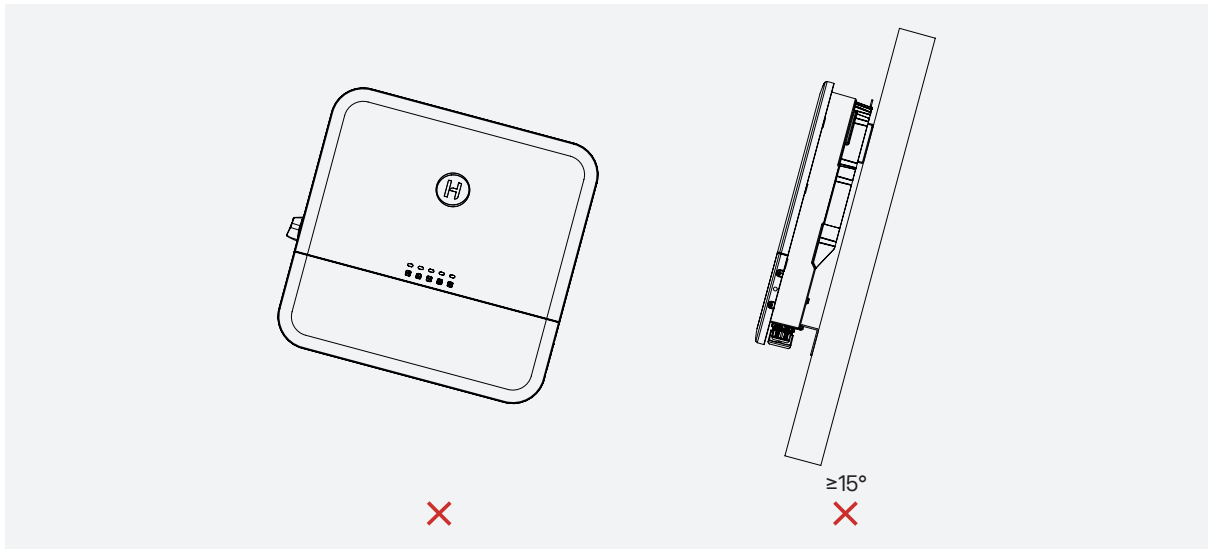

Figure 6-3 Incorrect Installation

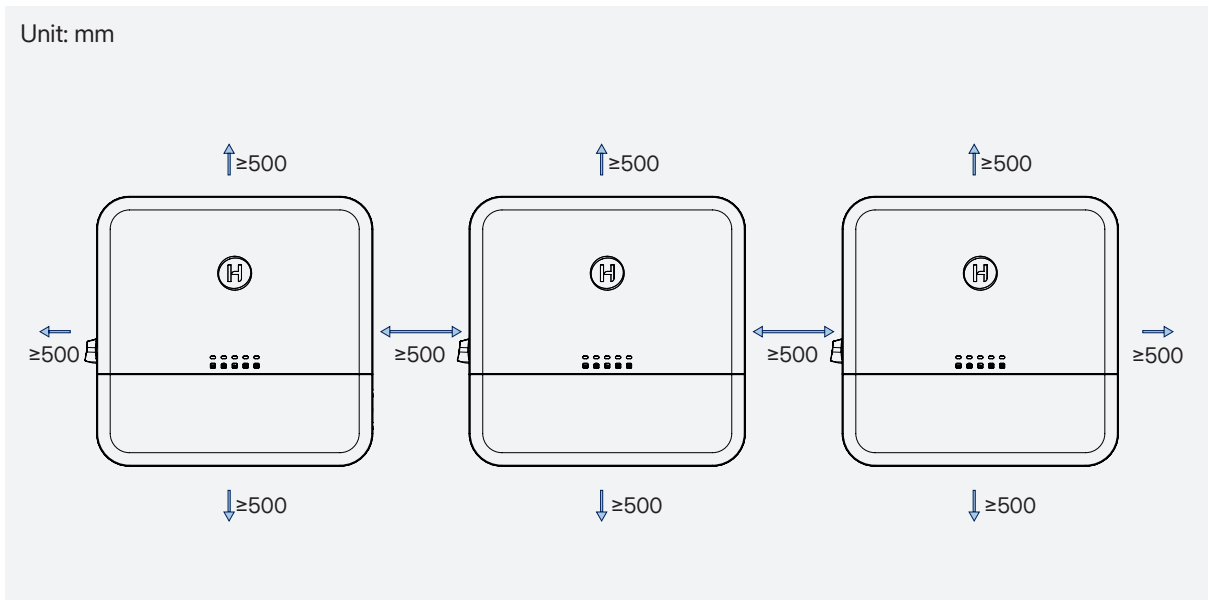
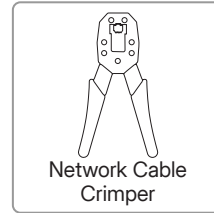
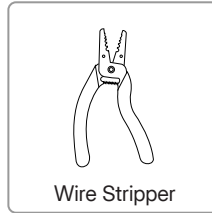
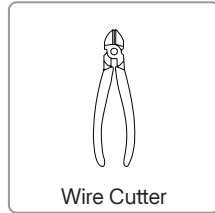
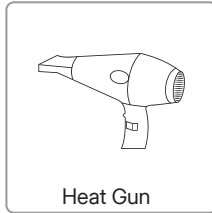
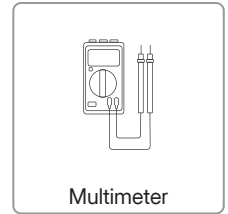
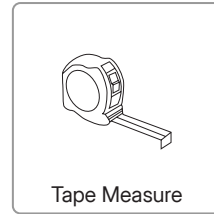
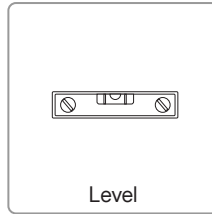
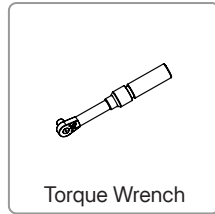
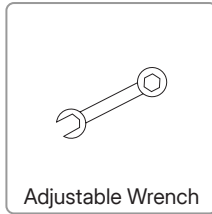
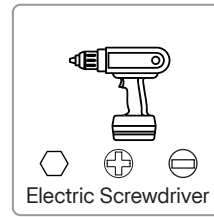
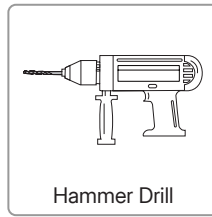
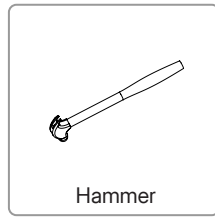
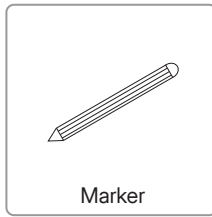

Figure 6-4 Multiple Inverters Installation

6.4 Installation Tools

The following tools are recommended in the installation process, and other auxiliary tools can also be used if necessary.



Personal Protective Equipment (PPE)



6.5 Installation Steps

Step 1 Place the positioning cardboard against the wall and mark the four hole positions.

Step 2 Drill holes with a diameter of 8 mm and a depth of 60 mm.

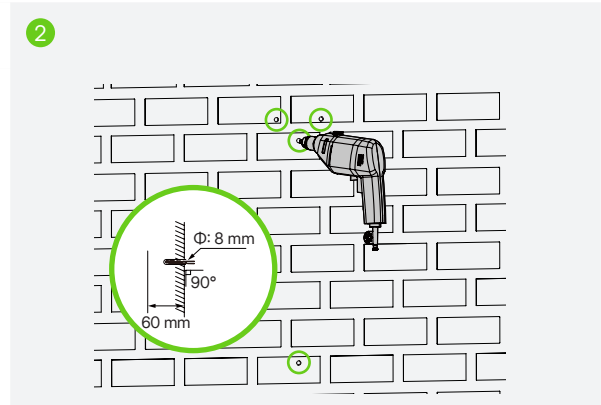
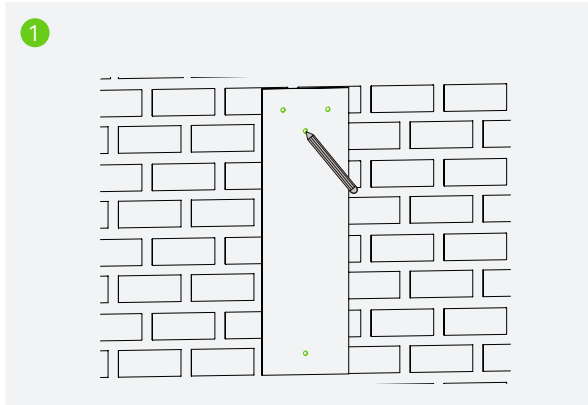

Step 3 Hammer the expansion screws into the holes and tighten them.

Step 4 Unscrew the screws while leaving sleeves in place.

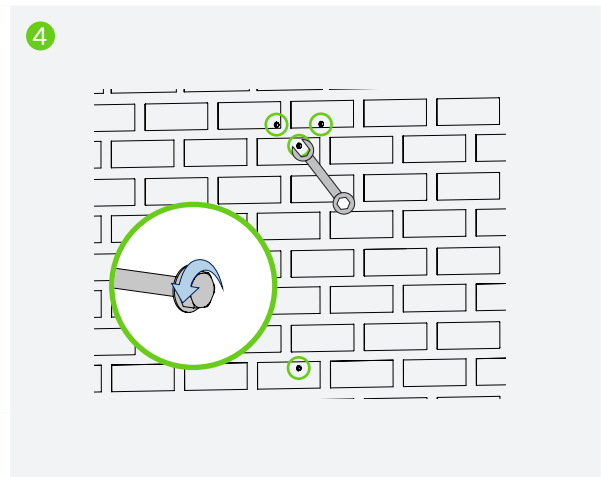
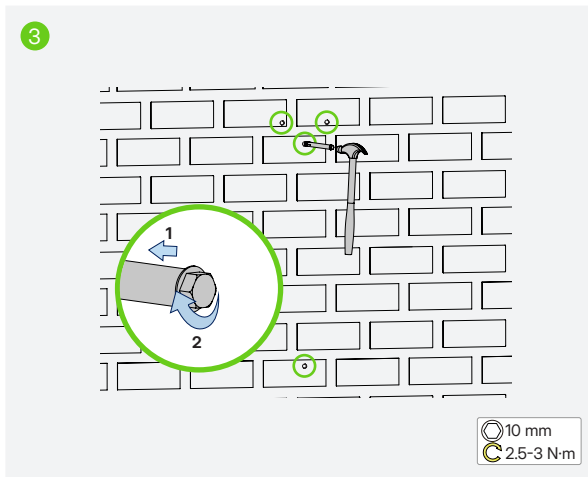

Step 5 Place the bracket A against the wall, insert the screws into the sleeves, and tighten them. Confirm that the bracket is firmly attached to the mounting surface.

Step 6 Unscrew the two screws on the right side of the inverter.

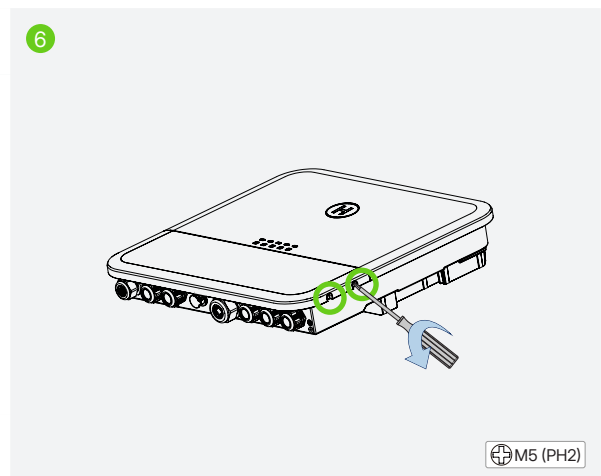
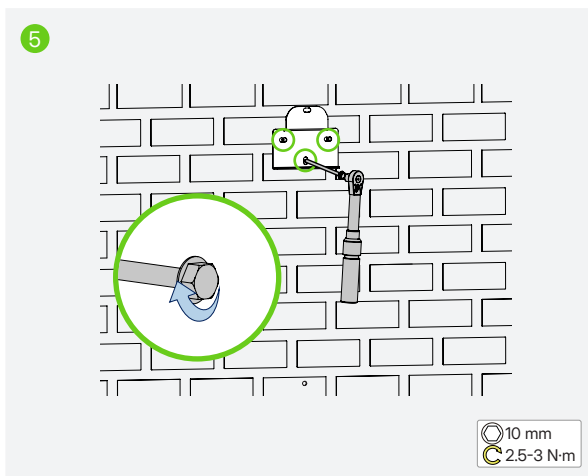

Step 7 Remove the wiring box cover.

Step 8 Hang the inverter on the bracket A.

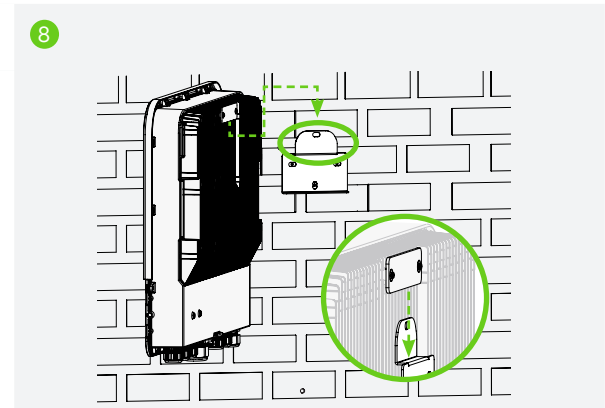
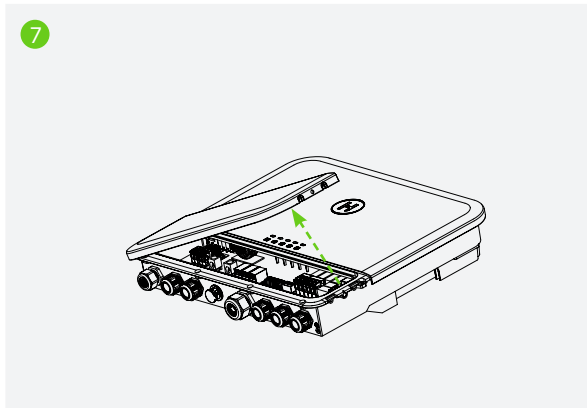

Step 9 Slightly pull the inverter bottom backwards and hang the bracket B on the mounting point at the back of the inverter.

Step 10 Insert the screw into the sleeve and tighten it.

Step 11 (Optional) Hang a lock on the top of the mounting bracket if necessary.

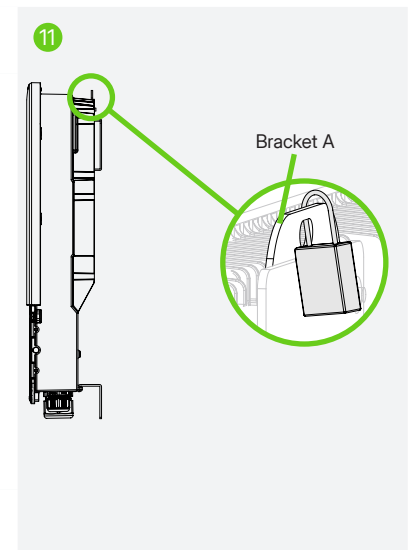
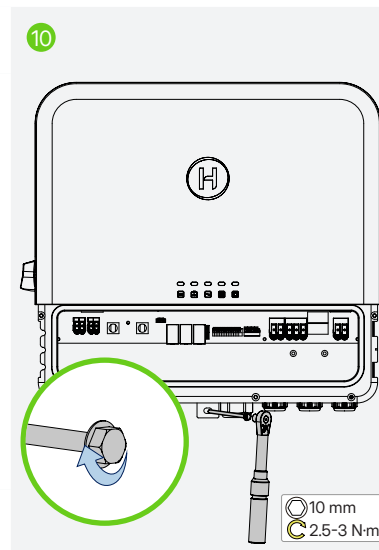
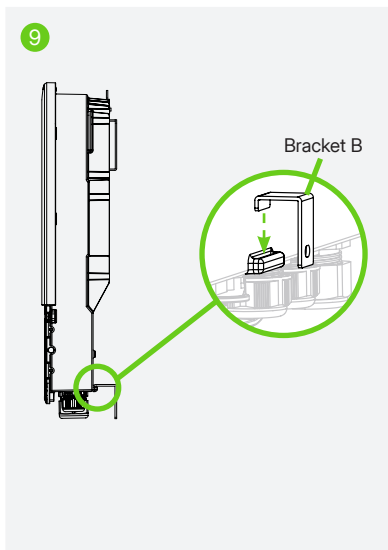

7 Electrical Connection

⚠ WARNING

- Before any electrical connections, keep in mind that the inverter has dual power supplies.
- The qualified personnel must wear personal protective equipment (PPE) during electrical work.
- To ensure safe connection and operation, it is recommended to install an overcurrent protection device (circuit breaker) while connecting battery cables, grid cable, EPS cable, and GEN cable.

7.1 Wiring Diagram

Diagram for Australia, New Zealand, South Africa, etc.

NOTICE

- This diagram illustrates an application where the neutral connects with PE in the distribution box.
- Please follow local wiring regulations.

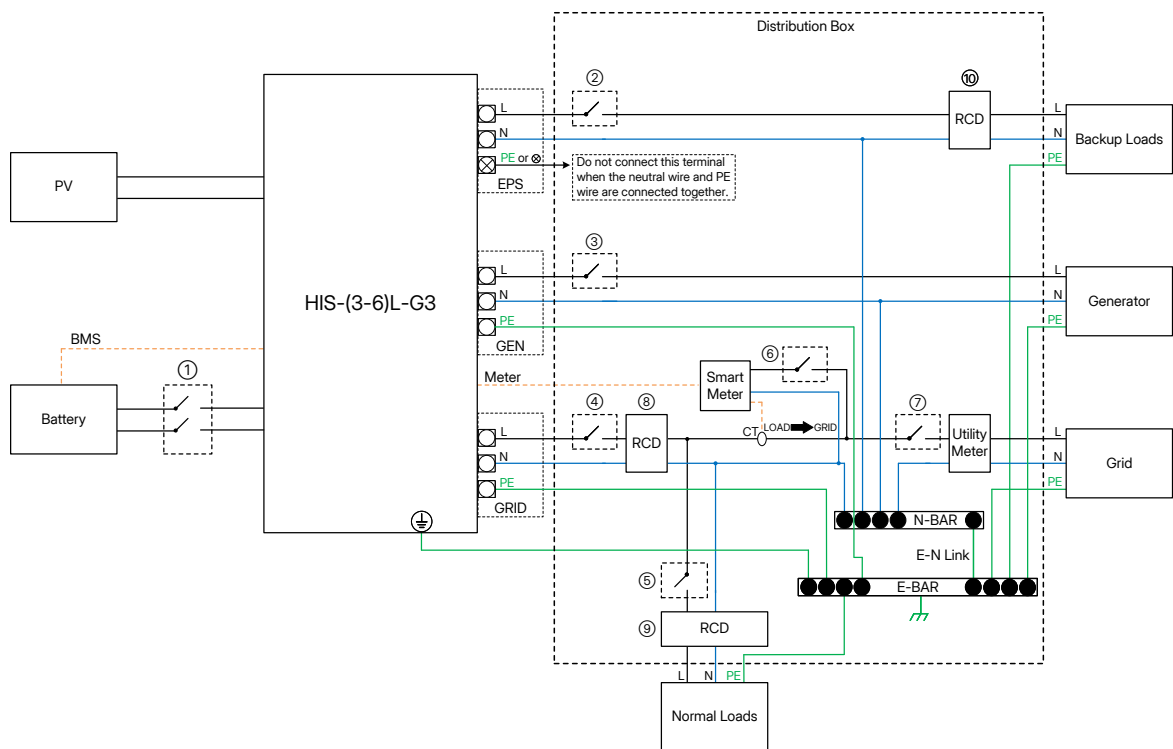

Figure 7-1 Basic Diagram 1

Model	①	②	③	④	⑤	⑥	⑦	⑧	⑨⑩
HIS-3L-G3	100 A/60 V DC Breaker	20 A/230 V AC Breaker	63 A/230 V AC Breaker	63 A/230 V AC Breaker					
HIS-3.6L-G3	125 A/60 V DC Breaker	25 A/230 V AC Breaker	63 A/230 V AC Breaker	63 A/230 V AC Breaker					
HIS-4.6L-G3	160 A/60 V DC Breaker	32 A/230 V AC Breaker	63 A/230 V AC Breaker	63 A/230 V AC Breaker	Depends on Loads	Depends on Meter	Main Breaker	300 mA RCD	30 mA RCD
HIS-5L-G3	160 A/60 V DC Breaker	32 A/230 V AC Breaker	63 A/230 V AC Breaker	63 A/230 V AC Breaker					
HIS-6L-G3	160 A/60 V DC Breaker	40 A/230 V AC Breaker	63 A/230 V AC Breaker	63 A/230 V AC Breaker					

NOTE

Since Hoymiles inverter has a built-in leakage current detection circuit, it is recommended to use a Type A RCD. If required by local regulations, a Type B RCD is also permitted.

Diagram for other countries

NOTICE

- This diagram illustrates an application where the neutral is separated from the PE in the distribution box.
- This diagram is for countries such as China, Germany, and Italy. Please follow local wiring regulations.
- The backup PE wire and earthing bar must be grounded properly and effectively. Otherwise, the backup function may be abnormal when the grid fails.

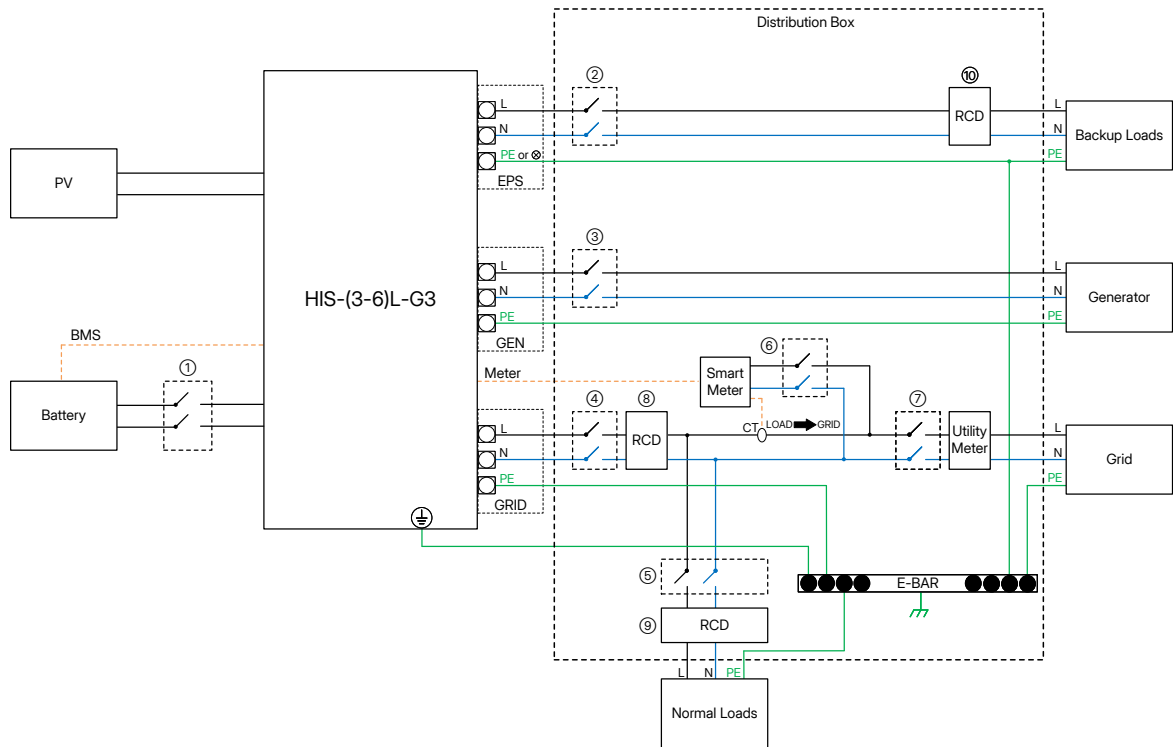

Figure 7-2 Basic Diagram 2

Model	①	②	③	④	⑤	⑥	⑦	⑧	⑨⑩
HIS-3L-G3	100 A/60 V DC Breaker	20 A/230 V AC Breaker	63 A/230 V AC Breaker	63 A/230 V AC Breaker					
HIS-3.6L-G3	125 A/60 V DC Breaker	25 A/230 V AC Breaker	63 A/230 V AC Breaker	63 A/230 V AC Breaker					
HIS-4.6L-G3	160 A/60 V DC Breaker	32 A/230 V AC Breaker	63 A/230 V AC Breaker	63 A/230 V AC Breaker	Depends on Loads	Depends on Meter	Main Breaker	300 mA RCD	30 mA RCD
HIS-5L-G3	160 A/60 V DC Breaker	32 A/230 V AC Breaker	63 A/230 V AC Breaker	63 A/230 V AC Breaker					
HIS-6L-G3	160 A/60 V DC Breaker	40 A/230 V AC Breaker	63 A/230 V AC Breaker	63 A/230 V AC Breaker					

NOTE
 Since Hoymiles inverter has a built-in leakage current detection circuit, it is recommended to use a Type A RCD. If required by local regulations, a Type B RCD is also permitted.





7.2 Recommended Cable List

The following table provides the cable specifications recommended by Hoymiles. The cables used in actual installation can be larger than the recommended specifications, but cannot be smaller than the recommended specifications. Select the appropriate cables in accordance with local laws and regulations.

NOTE

To ensure a reliable electrical connection, it is recommended to use crimp terminals when connecting cables to the inverter.

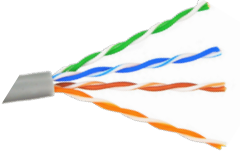
Cable (90°C, Copper)	Recommended Specification (mm ²)					Stripping Length (mm)
	HIS-3L-G3	HIS-3.6L-G3	HIS-4.6L-G3	HIS-5L-G3	HIS-6L-G3	
Ground	10					10
PV	4					12
Battery	16-25	25-35	35-50	35-50	35-50	18
GRID/EPS/GEN	10					18
COM1	Standard CAT 5E/CAT 6 Ethernet Cable					/
COM2	0.5-0.8					11

Cable	Picture	Type
Ground		Yellow-green cable
PV		Dedicated PV cable with a voltage rating of more than 550 V, a temperature resistance of 105°C, and a fire resistance grade of VW-1
GRID/EPS/GEN		Three-core copper cable
COM1		Standard CAT 5E/CAT 6 Ethernet cable
COM2		Two-core signal cable

7.3 Internal Overview

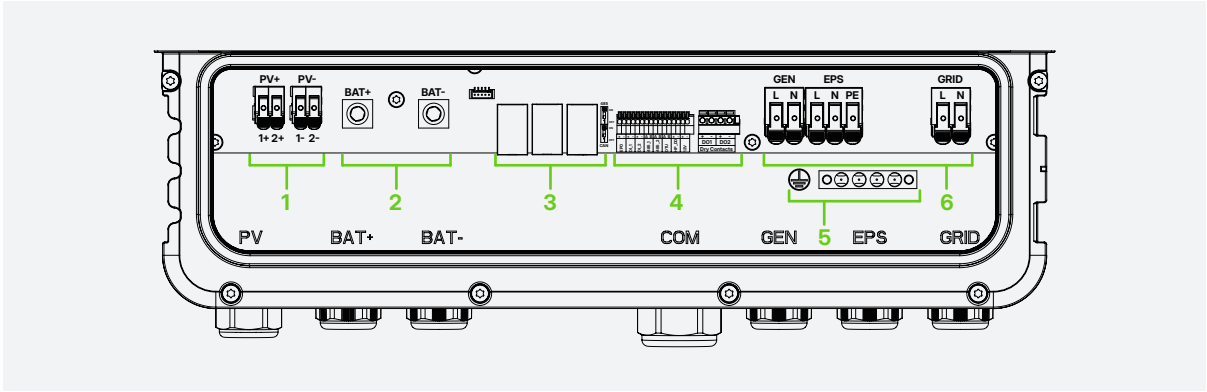

Figure 7-3 Internal Overview

NO.	Description
1	PV Terminals
2	Battery Terminals
3	Communication Terminals (COM1)
4	Communication Terminals (COM2)
5	Grounding Bar
6	AC Terminals

7.4 Ground Cable Connection

Cable (90°C, Copper)	Recommended Specification (mm ²)					Stripping Length (mm)
	HIS-3L-G3	HIS-3.6L-G3	HIS-4.6L-G3	HIS-5L-G3	HIS-6L-G3	
Ground	10					10

Step 1 Crimp the ground cable and ground terminal.

Step 2 Connect the ground cable to the inverter.

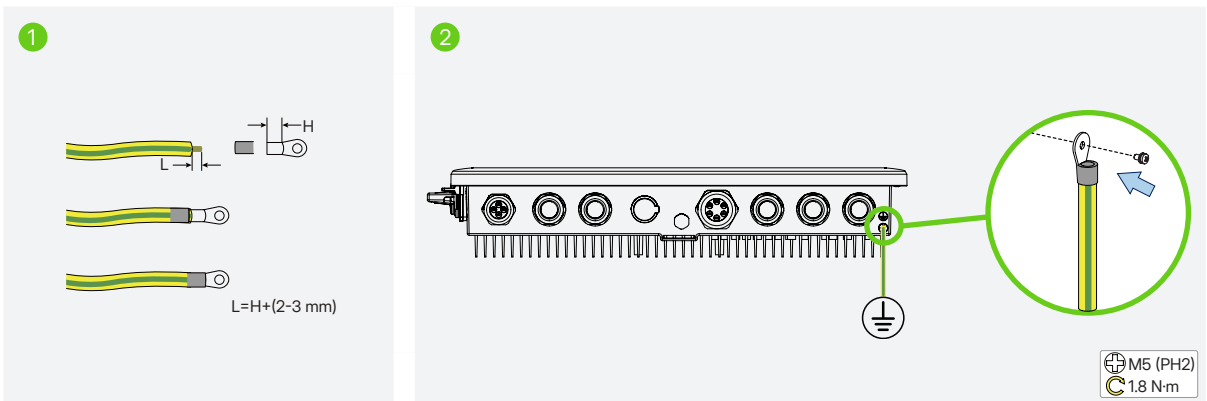

7.5 PV Cable Connection

⚠ WARNING

Before connecting the PV cables, please make sure all requirements listed below are followed.

- The voltage, current, and power ratings of the panels to be connected are within the allowable range of the inverter. Ensure the polarity is correct, and please refer to the technical parameters in [12 Technical Datasheet](#) for voltage and current limits.
- If the PV cables are reversely connected or if the equipment is not working properly, do not turn off the DC switch. Otherwise, it may cause a DC arc, fire, or damage to the inverter. After the PV input current drops below 0.5 A, disconnect the DC switch and adjust the polarity of the PV strings.
- Since the equipment is a transformerless structure, do not ground the outputs of PV panels.
- Check the cable connection of the PV strings for correct polarity, and ensure that, in any case, the open-circuit voltage does not exceed the inverter input limit of 550 V.

Cable (90°C, Copper)	Recommended Specification (mm ²)	Stripping Length (mm)
		HIS-3/3.6/4.6/5/6L-G3
PV	4	12

📌 NOTE

To ensure sealing performance, remove the rubber plugs based on the actual number of cables.

Step 1 Strip the cable insulation by 12 mm, unscrew the cable gland, and remove the rubber plugs.

Step 2 Thread the PV cables through the PV cable entry at the bottom.

Step 3 Thread the PV cables through the magnetic ring.

Step 4 Raise the locking clip.

Step 5 Insert the PV cables into the terminals according to positive and negative polarity.

Step 6 Pull the locking clip downward to lock the connection.

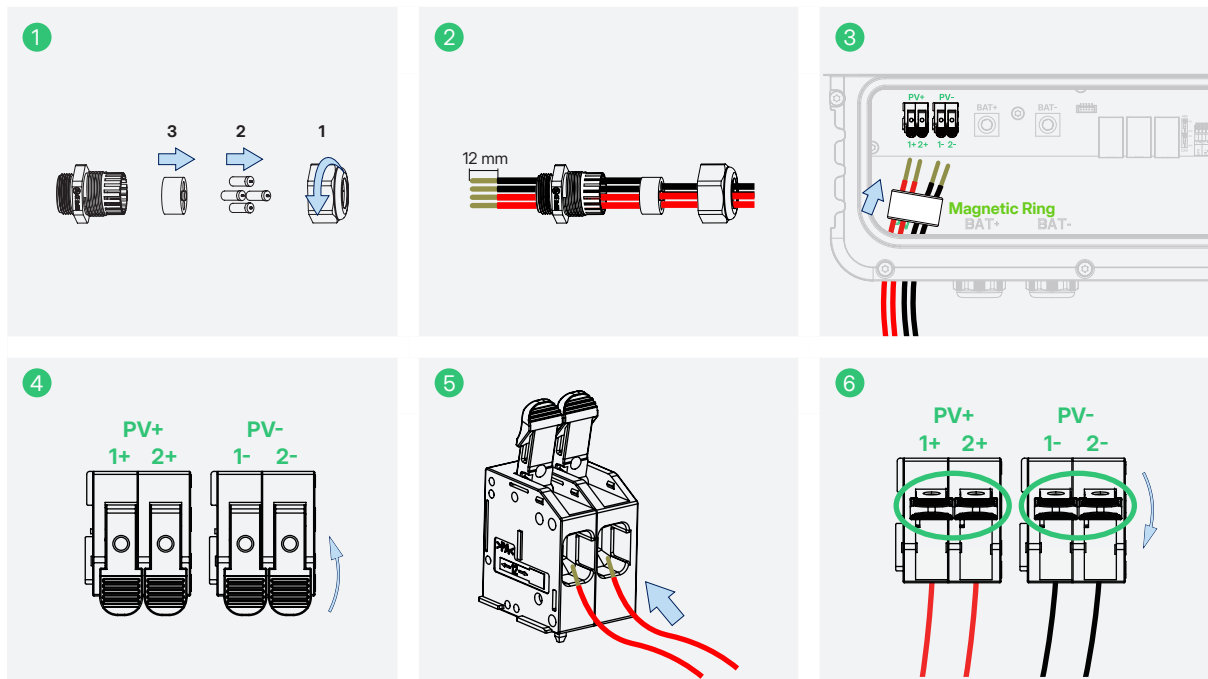

Step 7 Gently pull the cables backward to ensure that they are firmly connected, and tighten the cable gland.

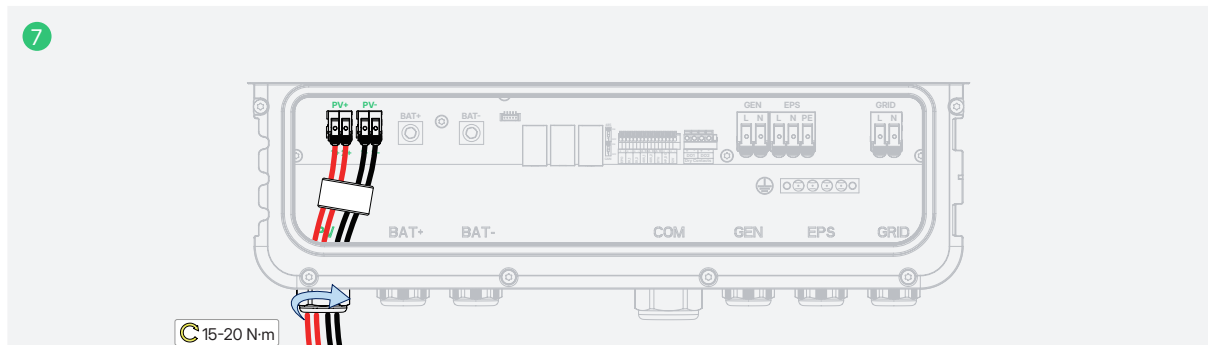

7.6 Battery Cable Connection

⚠ WARNING

Before connecting the battery cables, please make sure all requirements listed below are followed.

- A two-pole DC breaker with an overcurrent protection (OCP) function is compulsory to be installed between the inverter and battery. The battery may have this switch integrated. If not, an external DC switch of proper ratings should be used.
- Make sure the breaker mentioned above is in the "OFF" position.
- Check the cable connection of the battery for correct polarity, and ensure that, in any case, the open-circuit voltage does not exceed the inverter input limit of 60 V.

Before proceeding to the next step, make sure that the battery voltage is 0 V using a multimeter.

NOTICE

- Do not turn on the battery switch until all cables are properly connected.
- The inverter is compatible with specific batteries. For battery models that this inverter supports, refer to the [Hoymiles compatible battery list](#).

This section mainly describes the cable connections on the inverter side. For the cable connections on the battery side, refer to the documents provided by the battery manufacturer.

Cable (90°C, Copper)	Recommended Specification (mm ²)					Stripping Length (mm)
	HIS-3L-G3	HIS-3.6L-G3	HIS-4.6L-G3	HIS-5L-G3	HIS-6L-G3	HIS-3/3.6/4.6/5/6L-G3
Battery	16-25	25-35	35-50	35-50	35-50	18

Step 1 Strip the cable insulation by 18 mm, and unscrew the cable gland.

Step 2 Thread the battery cables through the BAT+ and BAT- cable entry at the bottom.

Step 3 Unscrew the bolts, insert the battery cables into the terminals, and tighten the bolts with a torque of 15.5 N·m.

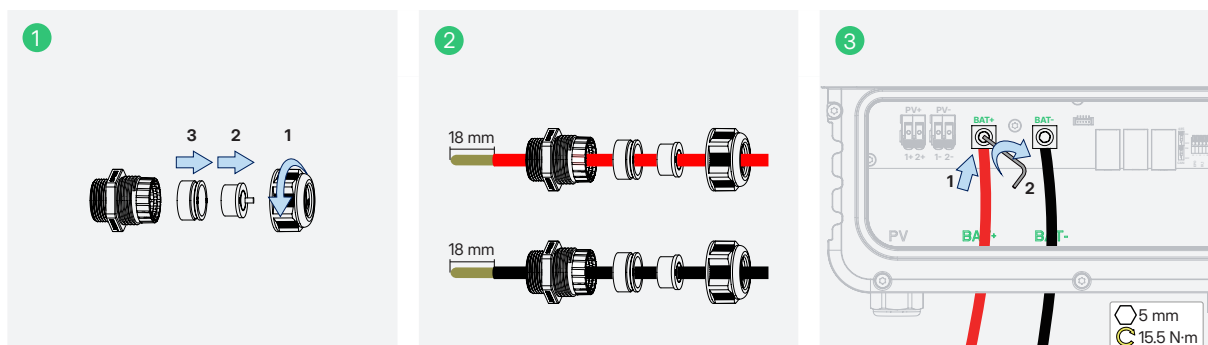

Step 4 Gently pull the cables backward to ensure that they are firmly connected, and tighten the cable glands.

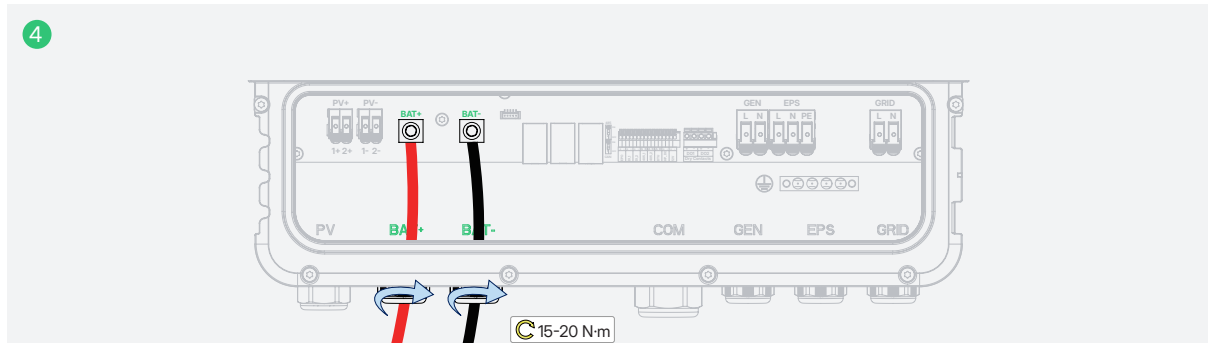

7.7 AC Cable Connection

⚠ WARNING

Before connecting the AC cable, please make sure all requirements listed below are followed.

- An independent two or three-pole circuit breaker must be installed on the output side of the inverter to ensure safe disconnection from the grid.
- Multiple inverters cannot share one circuit breaker.
- Never connect a load between the inverter and the circuit breaker.
- Make sure that the overcurrent protection devices (OCPDs) (breakers) are turned off.
- Ensure the rated power of the EPS load does not exceed the rated output power of the inverter.
- Ensure that the starting power of inductive loads, such as air conditioners, refrigerators, and pumps, does not exceed the EPS peak power of the inverter. (The starting power of the air conditioner is at least 2 times the rated power. For details, refer to the appliance manual.) Otherwise, the inverter will stop output or even shut down with a fault alarm.

Before proceeding to the next step, make sure that the AC voltages are 0 V using a multimeter.

📌 NOTE

- The colors for L, N, and PE wires used in this manual are L-Brown, N-Blue, and PE-Yellow&Green.
- The wiring color code may vary. Please follow local laws and regulations for wiring.

Cable (90°C, Copper)	Recommended Specification (mm ²)					Stripping Length (mm)
	HIS-3L-G3	HIS-3.6L-G3	HIS-4.6L-G3	HIS-5L-G3	HIS-6L-G3	
GRID/EPS/GEN	10					18

The following three sections take **HIS-6L-G3** as an example. For detailed cable specifications, refer to the recommended cable list above.

7.7.1 Grid Connection

- Step 1** Strip the insulation of L/N/PE wires by 18 mm, and unscrew the cable gland.
- Step 2** Thread L/N/PE wires through the GRID cable entry at the bottom.
- Step 3** Connect the PE wire to the grounding bar.
- Step 4** Raise the locking clip.
- Step 5** Insert L/N wires into the corresponding terminals.
- Step 6** Pull the locking clip downward to lock the connection.
- Step 7** Gently pull the wires backward to ensure that they are firmly connected, and tighten the cable gland.

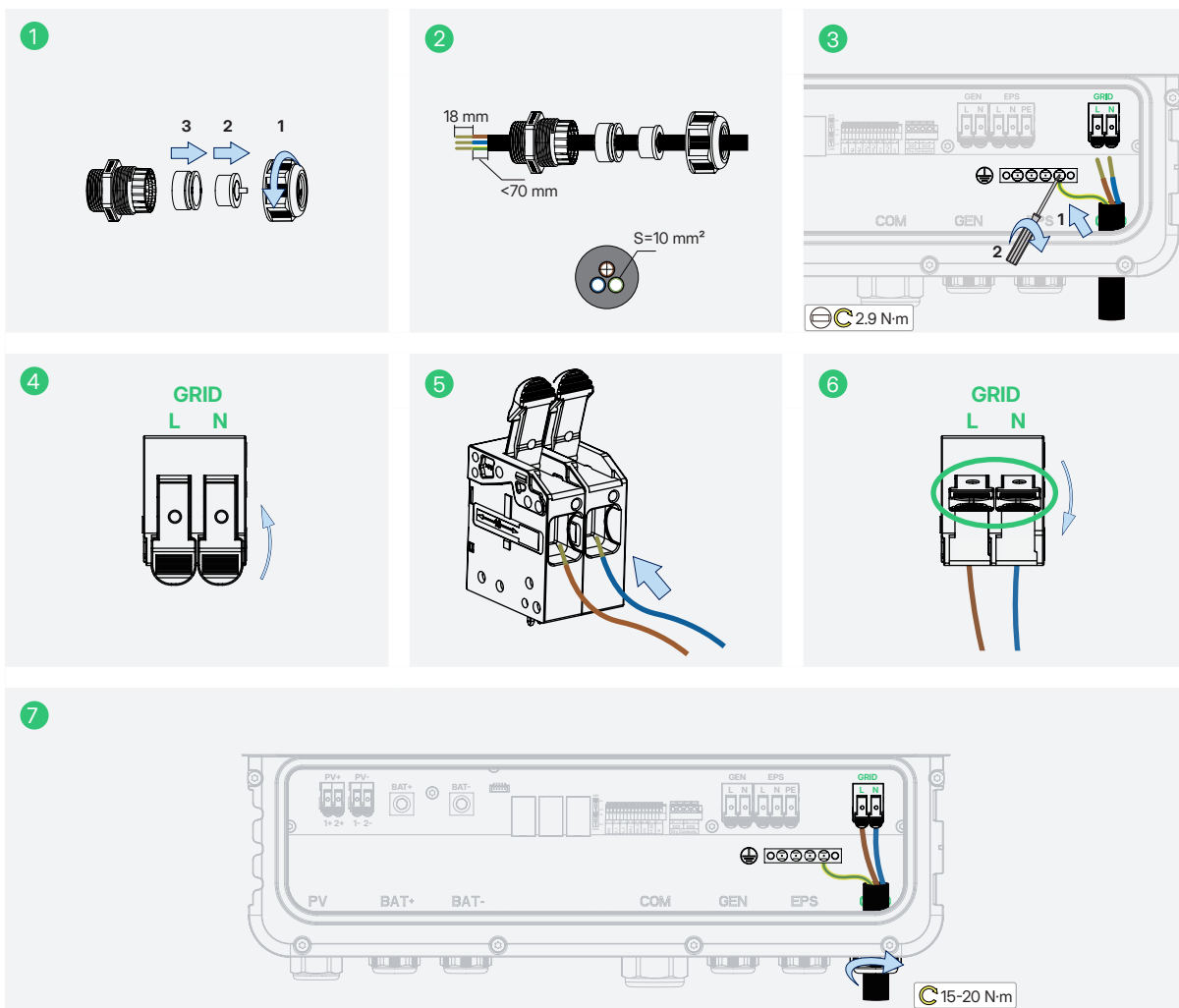

7.7.2 EPS Connection

- Step 1** Strip the insulation of L/N/PE wires by 18 mm, and unscrew the cable gland.
- Step 2** Thread L/N/PE wires through the EPS cable entry at the bottom.
- Step 3** Raise the locking clip.
- Step 4** Insert L/N/PE wires into the corresponding terminals.
- Step 5** Pull the locking clip downward to lock the connection.
- Step 6** Gently pull the wires backward to ensure that they are firmly connected, and tighten the cable gland.

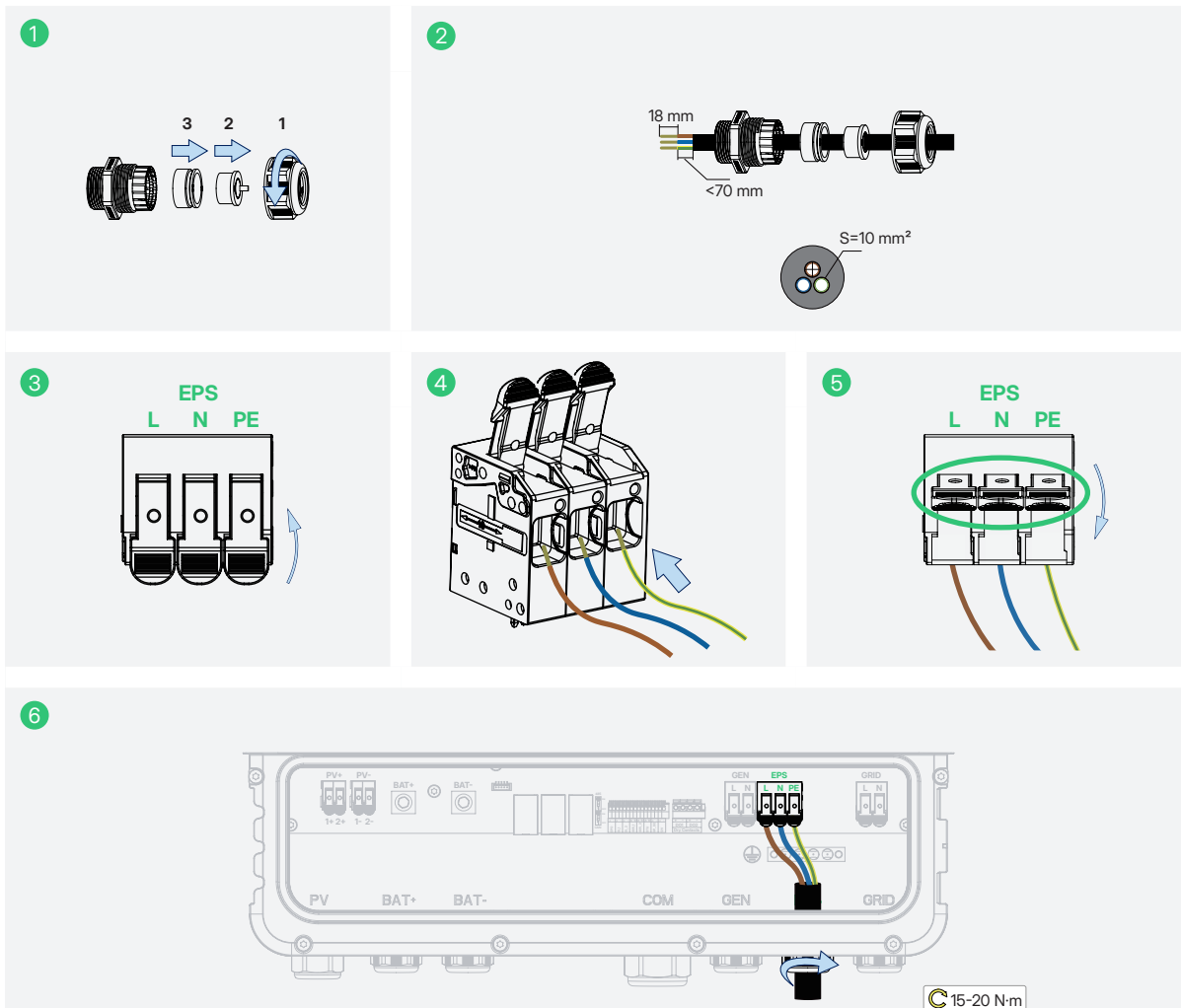

7.7.3 GEN Connection

- Step 1** Strip the insulation of L/N/PE wires by 18 mm, and unscrew the cable gland.
- Step 2** Thread L/N/PE wires through the GEN cable entry at the bottom.
- Step 3** Connect the PE wire to the grounding bar.
- Step 4** Raise the locking clip.
- Step 5** Insert L/N wires into the corresponding terminals.
- Step 6** Pull the locking clip downward to lock the connection.
- Step 7** Gently pull the wires backward to ensure that they are firmly connected, and tighten the cable gland.

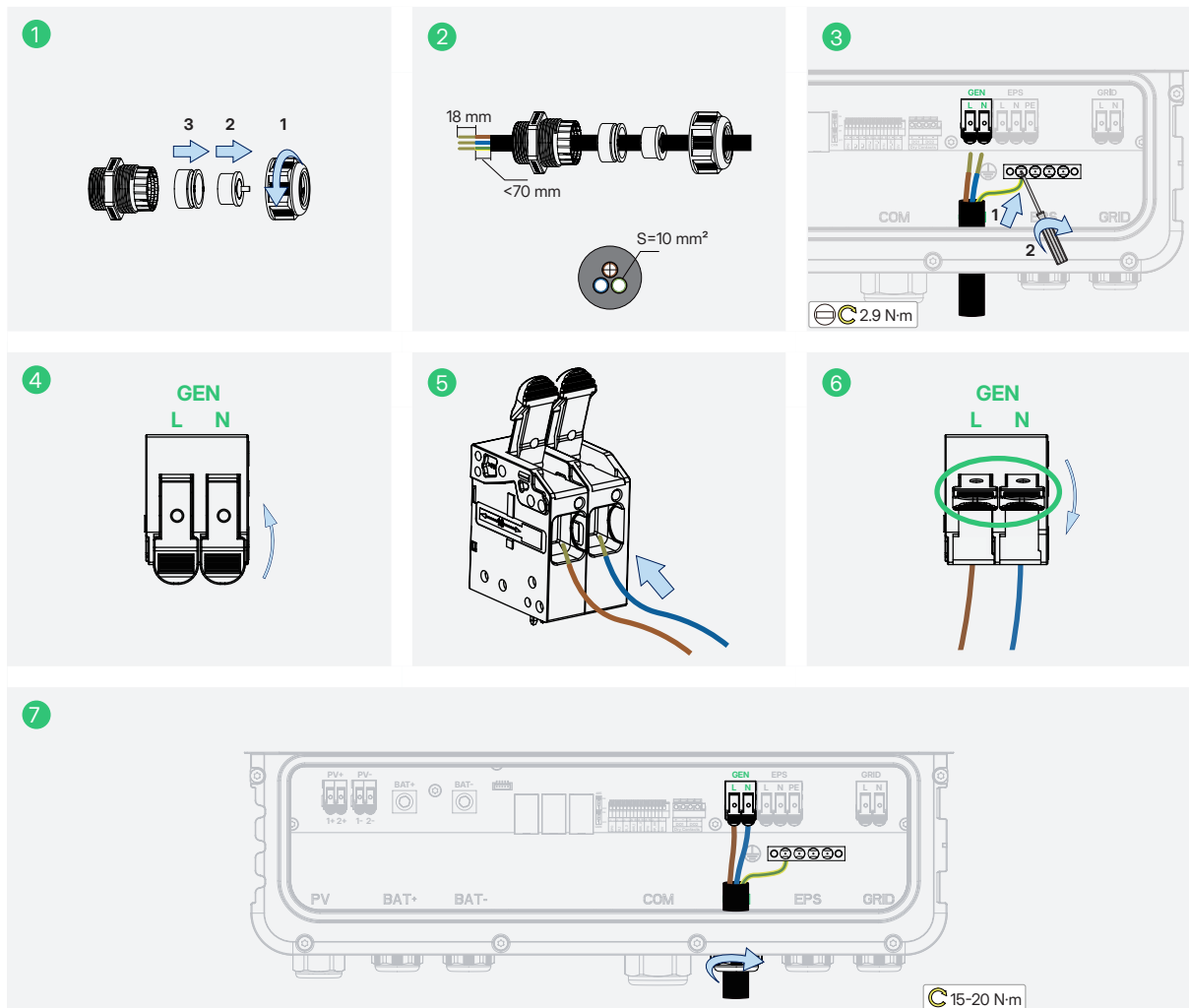

7.8 Communication Cable Connection (COM1)

The COM1 is used for parallel connection via Parallel_1 and Parallel_2 communication terminals, meter communication via Meter terminal, CT communication via CT terminal, battery communication via BMS terminal, and external communication via DRM terminal.

Cable	Recommended Specification (mm ²)
	HIS-3/3.6/4.6/5/6L-G3
COM1	Standard CAT 5E/CAT 6 Ethernet Cable

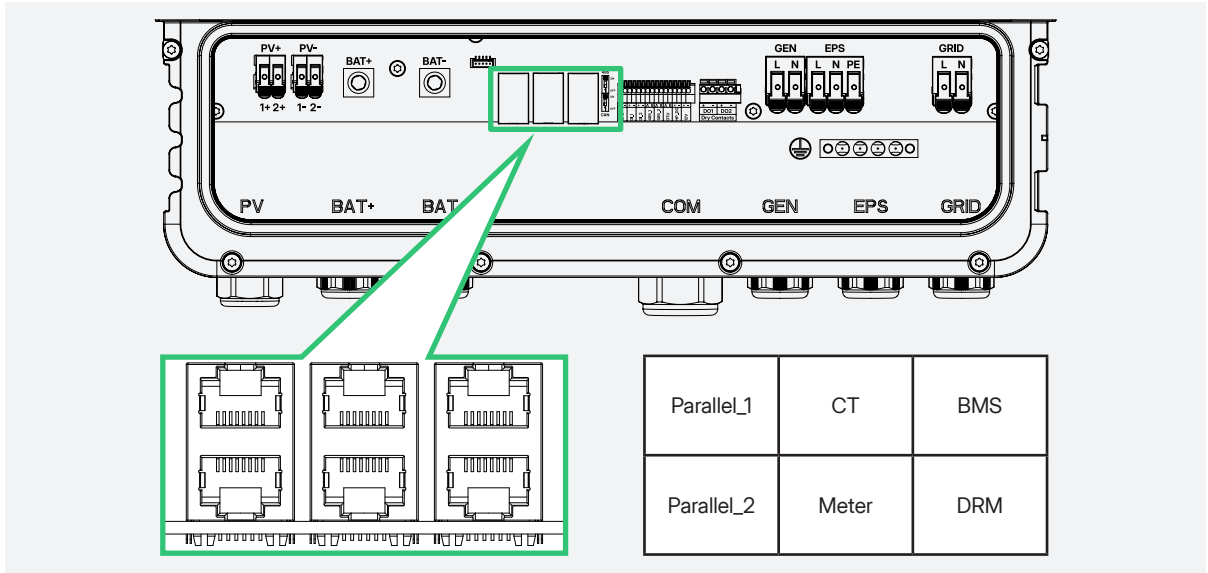

Figure 7-4 COM1 Overview

NOTE

The wiring sequence of the network cable for parallel terminals differs from that of a standard network cable. For details, see the table below.

Terminal	PIN	Definition							
		1	2	3	4	5	6	7	8
Parallel_1	87654321	NC	GND	CANH	CANL	RXD	TXD	485B	485A
Parallel_2	12345678	NC	GND	CANH	CANL	RXD	TXD	485B	485A
CT	87654321	IL+	NC	NC	NC	NC	NC	NC	IL-
Meter	12345678	NC	NC	NC	485A	485B	GND	NC	NC
BMS	87654321	NTC+	GND	NTC-	CANH	CANL	GND	NC	NC
DRM	12345678	DRM1/5	DRM2/6	DRM3/7	DRM4/8	REF	COM	NC	NC

Step 1 Prepare the network cable.

- a. Strip the insulation of the communication cable with an Ethernet wire stripper, and lead the corresponding signal cables out.
- b. Insert the stripped communication cable into the RJ45 plug in the correct order, and crimp it with a network cable crimper.

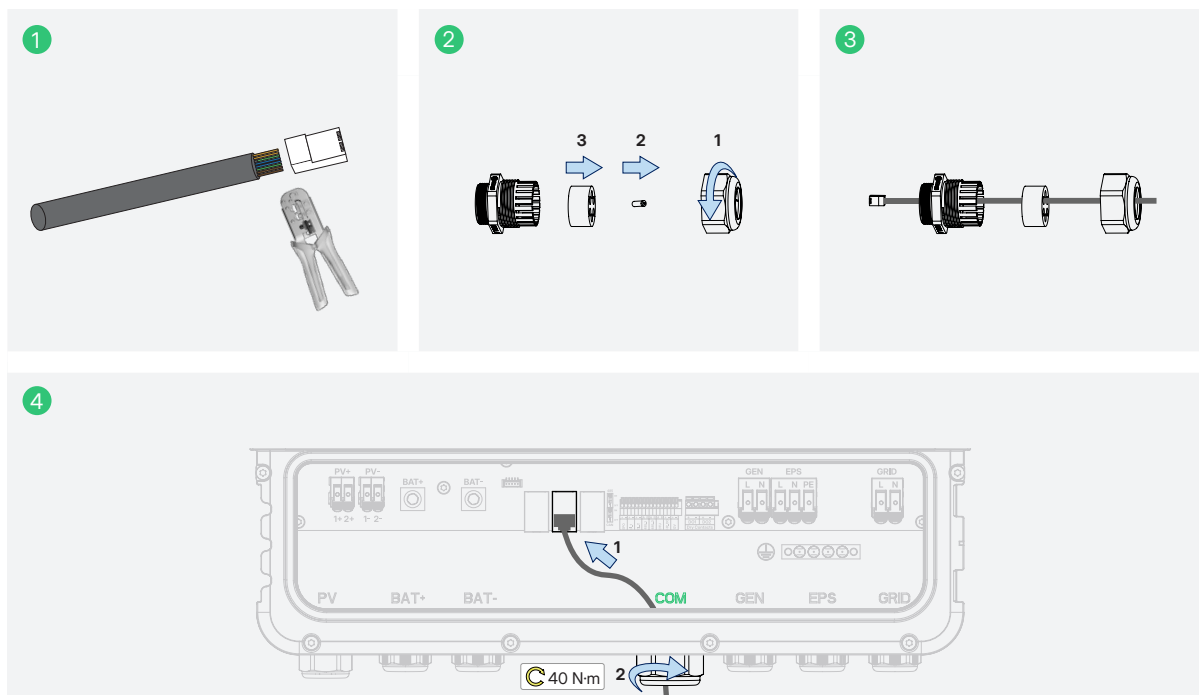
Step 2 Unscrew the cable gland, and remove the rubber plugs.**Step 3** Thread the cable through the communication cable entry at the bottom.**Step 4** Insert the RJ45 plug into the corresponding terminal until it clicks into place and tighten the cable gland.**NOTE**

- To ensure sealing performance, remove the rubber plugs based on the actual number of cables.
- If the wiring is incorrect, the system will work abnormally. Reconnect cables according to the PIN definition described above.

7.8.1 Parallel Connection

The inverter can support up to 10 inverters in parallel. The connection methods vary in different scenarios. For details, refer to [14 Appendix 2: Application of Parallel Function](#).

7.8.2 Smart Meter and CT Connection

The smart meter and CT in the accessory box are necessary for the system installation and are used to provide the operating condition of the inverter via RS485 communication.

WARNING

Before connecting the smart meter and CT, ensure that the AC cables are totally isolated from the AC power source.

NOTICE

- One smart meter can be used with only one inverter.
- There is an arrow or label on the surface of CT that indicates the correct mechanical orientation of the CT on the conductor under measurement. Please identify the arrow or label before installing the CT.

There are two schemes, one is the smart meter and CT scheme, and the other is CT scheme. Detailed connection methods are shown as follows.

Smart Meter and CT Scheme

- Step 1** Respectively connect meter’s terminals L1 and N to Grid L and N.
- Step 2** Clamp the CT onto Grid L. Ensure the arrow on the surface of the CT points to the grid.
- Step 3** Connect the CT to the meter’s CT1 terminal.
- Step 4** Use a standard Ethernet cable to connect the meter’s RS485 terminal and the inverter’s meter terminal.

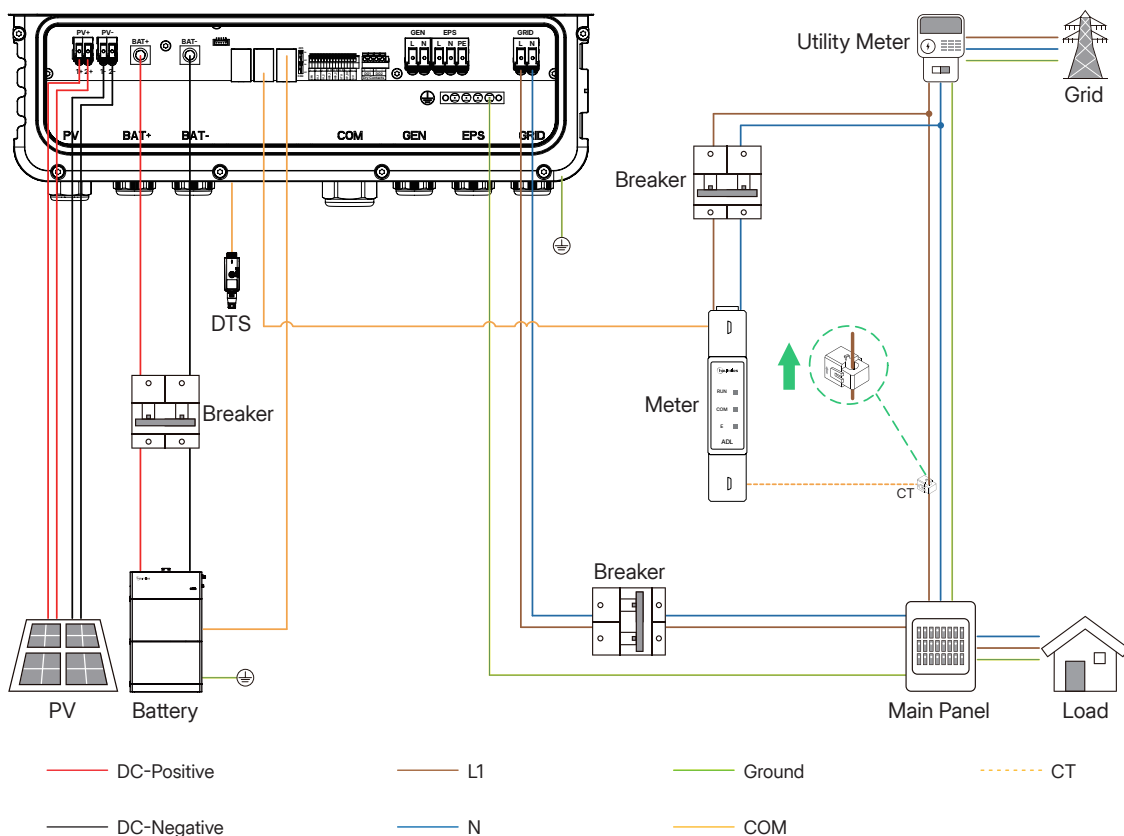

Figure 7-5 Smart Meter and CT Connection

CT Scheme

Step 1 Clamp the CT onto Grid L. Ensure the arrow on the surface of the CT points to the grid.

Step 2 Connect the CT to the inverter's CT terminal.

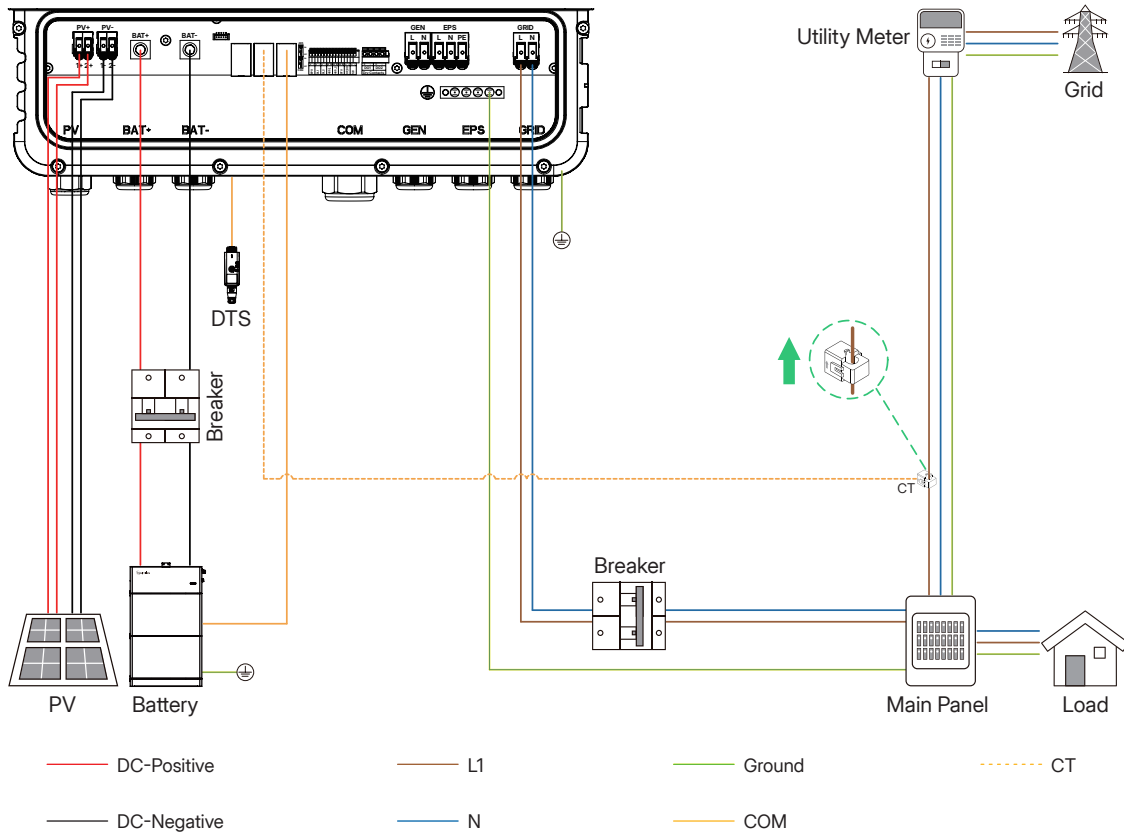

Figure 7-6 CT Connection

7.8.3 BMS Connection

The inverter can communicate with the battery through the BMS terminal. Note that the PIN definition should be correct as described in [7.7 Communication Cable Connection \(COM1\)](#). The Li-ion battery connection method is shown as follows, and the lead-acid battery connection method is shown in [15 Appendix 3: Application of Lead-acid Battery](#).

NOTE

- For detailed connection method of batteries, refer to documents provided by the battery manufacturer.
- If the battery has a circuit breaker integrated, there is no need to install a circuit breaker between the inverter and the battery.

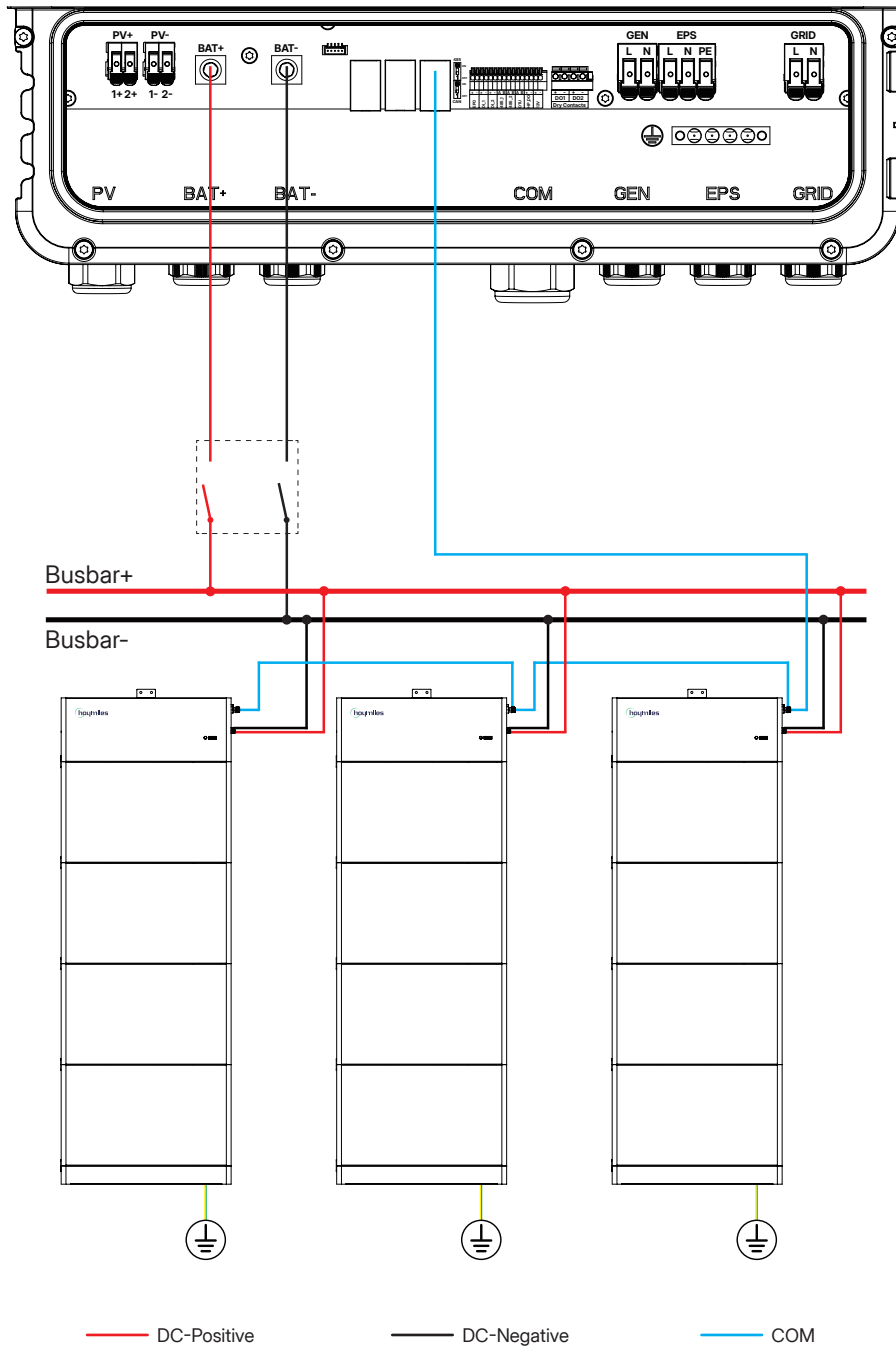

Figure 7-7 BMS Connection

7.8.4 DRM Connection

DRM is designed to support several demand response modes by certain control signals.

NOTE

After completing the DRM connection, log in to the S-Miles Installer App to enable the DRM function and set the mode of **DRM Control** according to the actual installation. For detailed instructions, refer to [9.3.2 Enable DRM Function](#).

- For Australia and New Zealand**

According to AS/NZS 4777.2, the inverter needs to support the function of demand response mode (DRM). With the use of an external control box, active or reactive power regulation can be realized in a timely and fast manner, and the inverter can work stably during the process of regulation.

Demand Response Modes

Function	Description
DRM0	Operate the disconnection device
DRM1	Do not consume power
DRM2	Do not consume at more than 50% of rated power
DRM3	Do not consume at more than 75% of rated power AND supply reactive power if capable
DRM4	Increase power consumption (subject to constraints from other active DRMs)
DRM5	Do not generate power
DRM6	Do not generate at more than 50% of rated power
DRM7	Do not generate at more than 75% of rated power AND absorb reactive power if capable
DRM8	Increase power generation (subject to constraints from other active DRMs)

DRED Connection Circuit

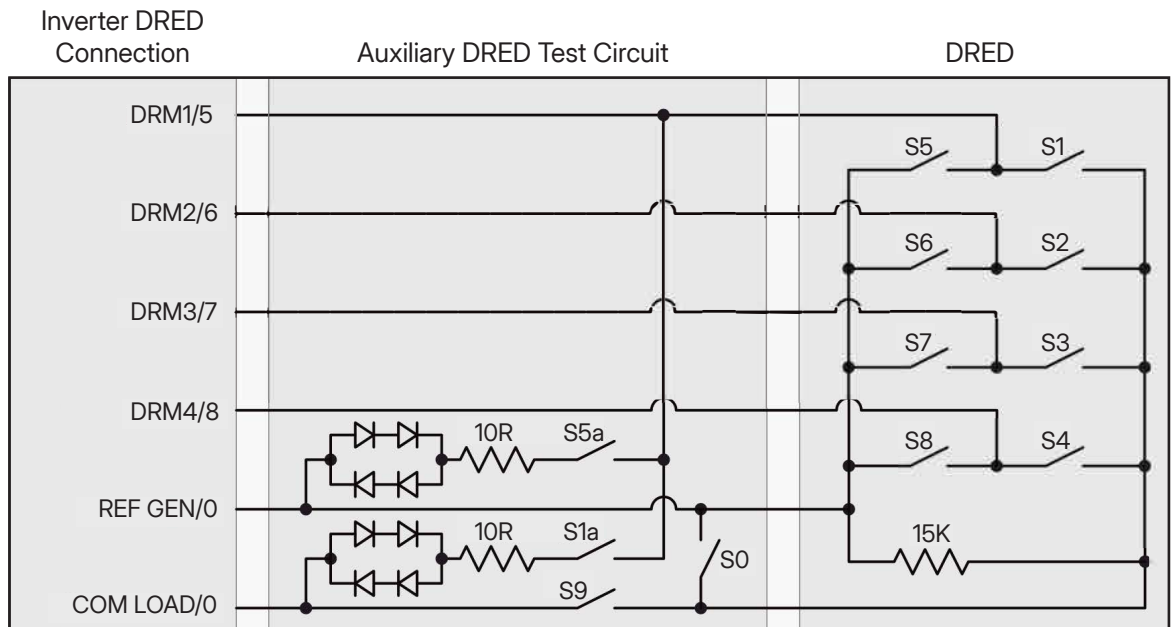

Figure 7-8 DRED Connection

- **For Germany**

In Germany, the inverters are required to respond to control signals from the grid company via a Ripple Control Receiver (RCR). The RCR converts dispatch signals from the grid operator into dry contact signals, which the inverter uses to limit its feed-in power as instructed.

The internal wiring and operation description are shown in the figure below.

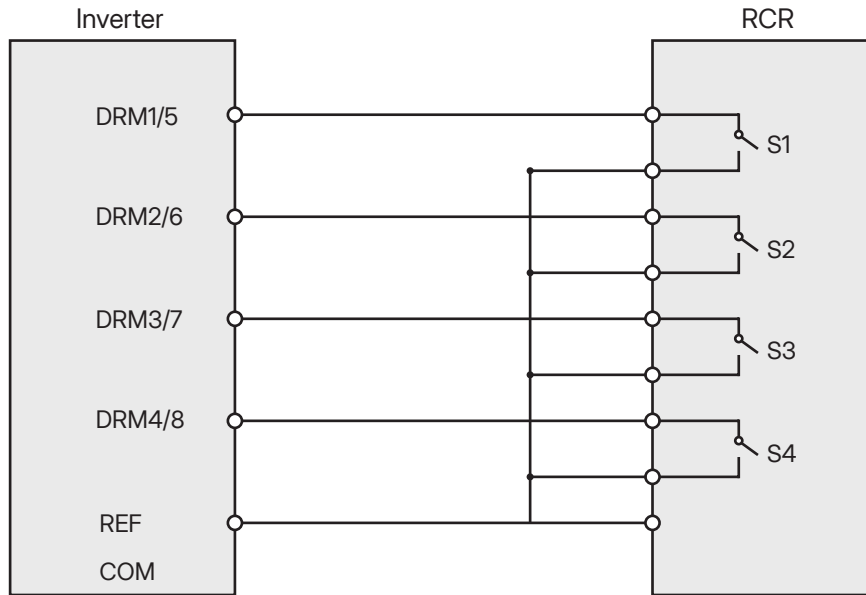

Figure 7-9 RCR Connection

S1	S2	S3	S4	RCR Operation	Output power (100% Rated Output Power)
0	0	0	0	None	100% (Unlimited)
1	0	0	0	Close S1	100%
0	1	0	0	Close S2	60%
0	0	1	0	Close S3	30%
0	0	0	1	Close S4	0

- **For Austria**

An external contactor should be connected to DRM4/8 and REF. Select a NO contactor or a NC contactor as required.

7.9 Communication Cable Connection (COM2)

Cable	Recommended Specification (mm ²)	Stripping Length (mm)
		HIS-3/3.6/4.6/5/6L-G3
COM2	0.5-0.8	11

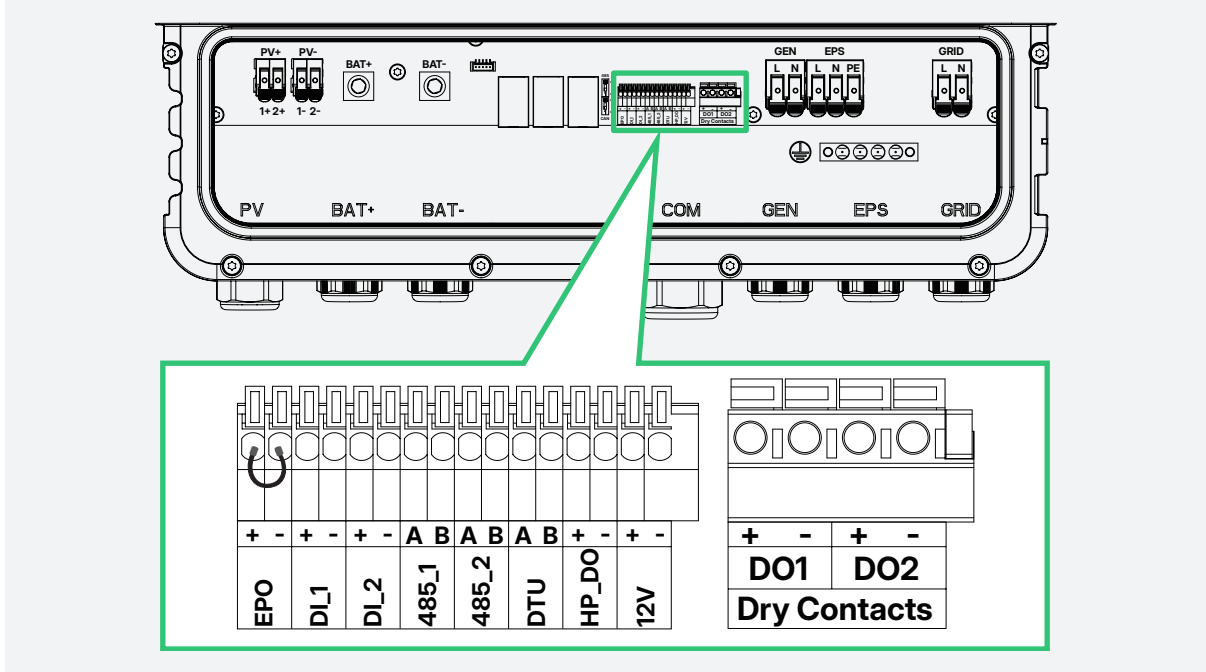
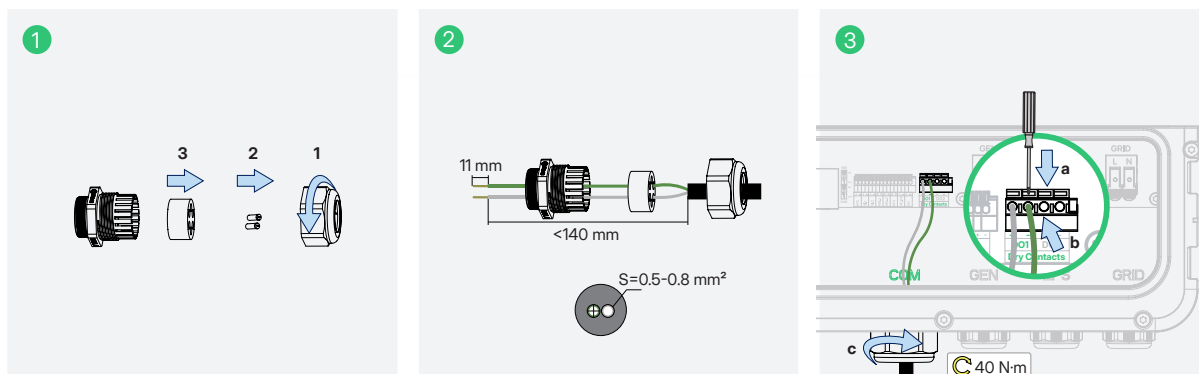

Figure 7-10 COM2 Overview

Label	Definition
EPO	For external Emergency Power Off switch.
DL1 (IN+, IN-)	Reserved dry contact input.
DL2 (IN+, IN-)	Dry contact input of external bypass contactor.
485_1	For the EV charger control.
485_2	For the third-party control and VPP operation.
DTU	For DTU communication.
HP_DO	For SG Ready heat pump control.
12V	(Optional) For SG Ready heat pump control.
DO1 (NO1, COM1)	Dry contact output. The DO1 can be set to one of the functions as follows: Earth Fault Alarm, Load Control, and Generator Control.
DO2 (NO2, COM2)	Dry contact output. The DO2 will control the bypass contactor under certain logic.

- Step 1** Strip the insulation of the communication cable by 11 mm, unscrew the cable gland, and remove the rubber plugs.
- Step 2** Thread the cable through the communication cable entry at the bottom.
- Step 3** Connect the cable.
- Insert a screwdriver to press down the leaf spring.
 - Insert the wires into the corresponding terminals, and remove the screwdriver.
 - Gently pull the wires backward to ensure that they are firmly connected, and tighten the cable gland.



NOTE

To ensure sealing performance, remove the rubber plugs based on the actual number of cables.

7.10 Installing the Wiring Box Cover

- Step 1** Put back the wiring box cover.
- Step 2** Press the right side of the wiring box cover to align the screw holes, insert the screws into the holes, and tighten the screws.

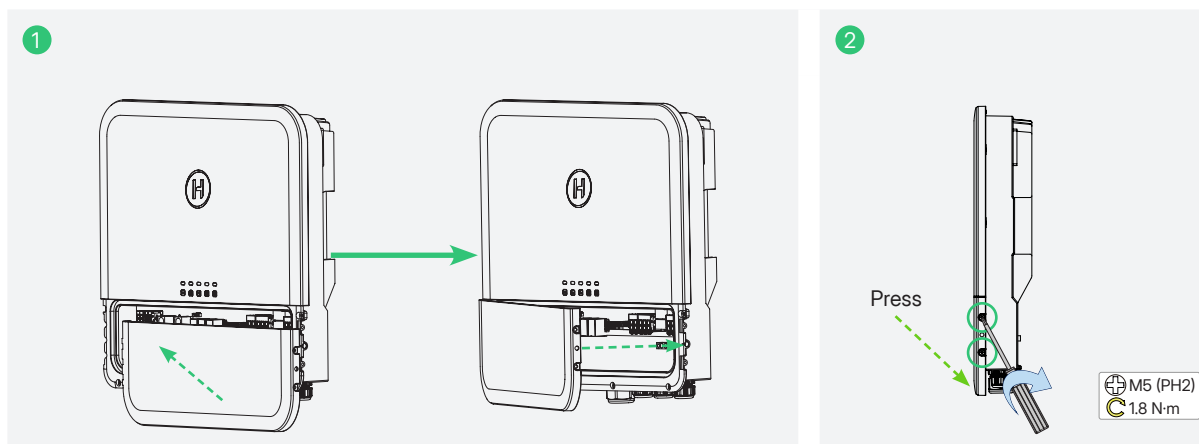

7.11 Installing the DTS

DTS-WL-G3 (Wi-Fi Mode)

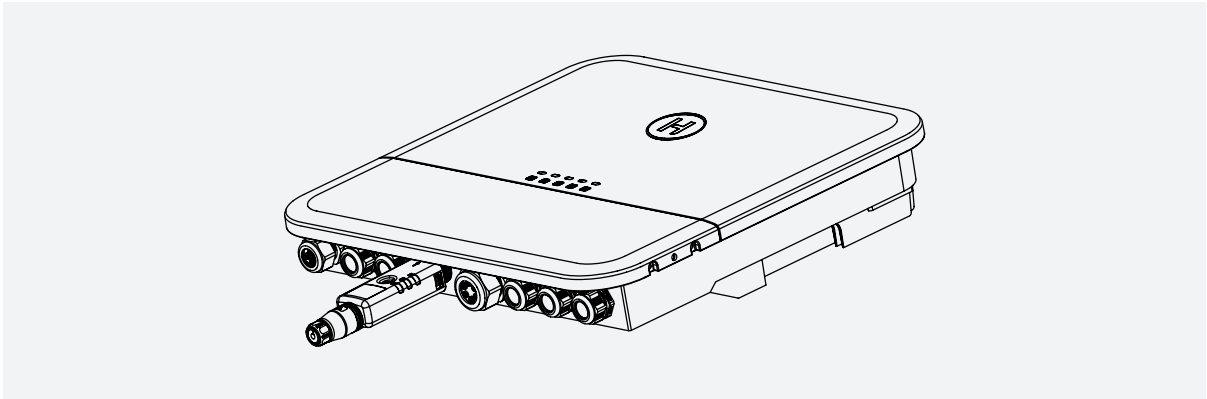

Step 1 Remove the cover of the DTS terminal.

Step 2 Insert the DTS into the DTS terminal. There will be a “Click” sound when it is plugged in correctly.

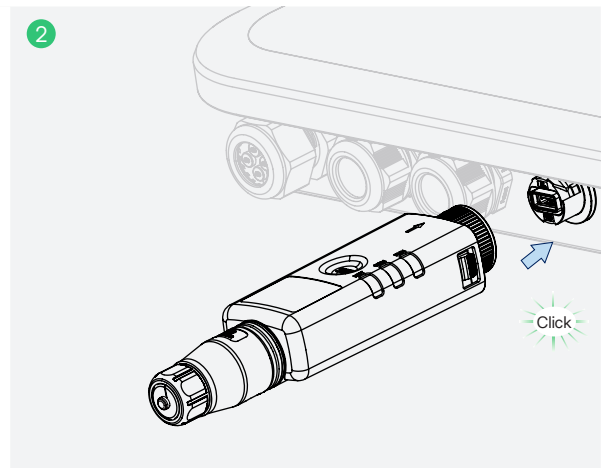
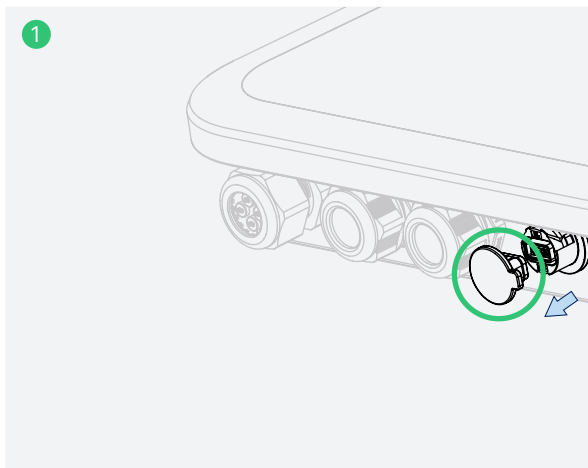

DTS-WL-G3 (LAN Mode)

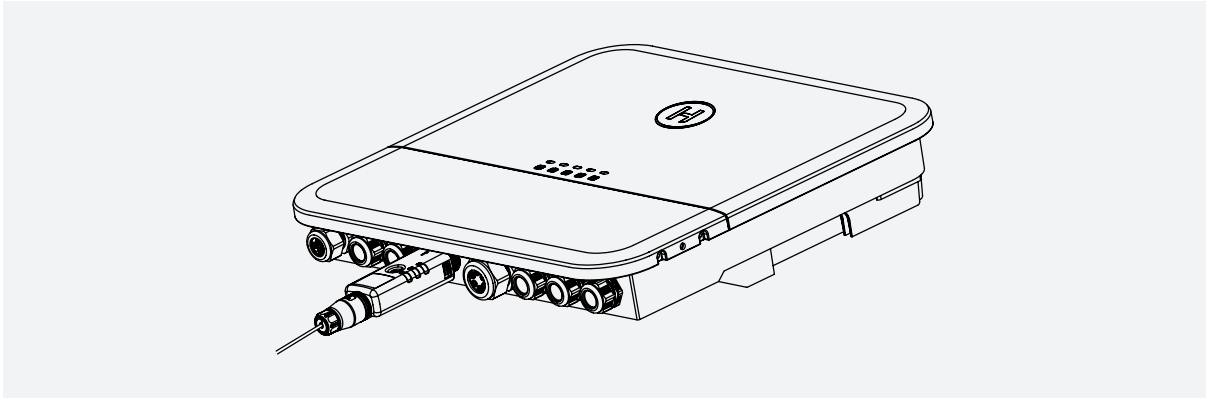

Step 1 Disassemble the DTS in sequence.

Step 2 Thread the Ethernet cable through the parts and tighten them.

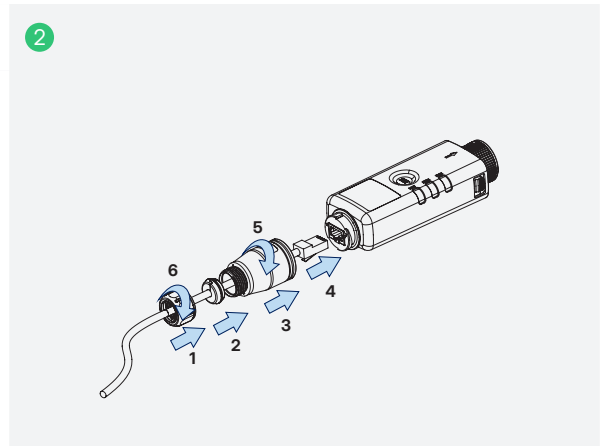
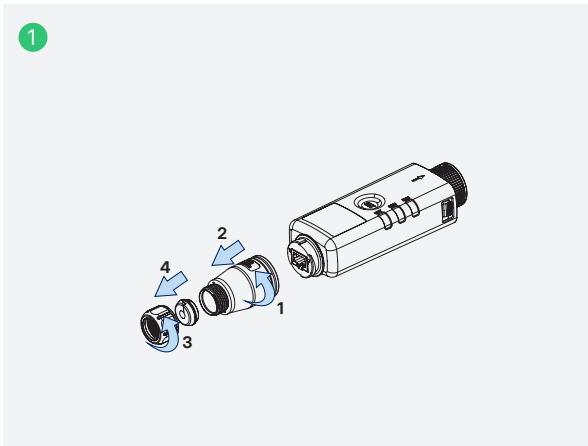

Step 3 Remove the cover of the DTS terminal.

Step 4 Insert the DTS into the DTS terminal. There will be a "Click" sound when it is plugged in correctly.

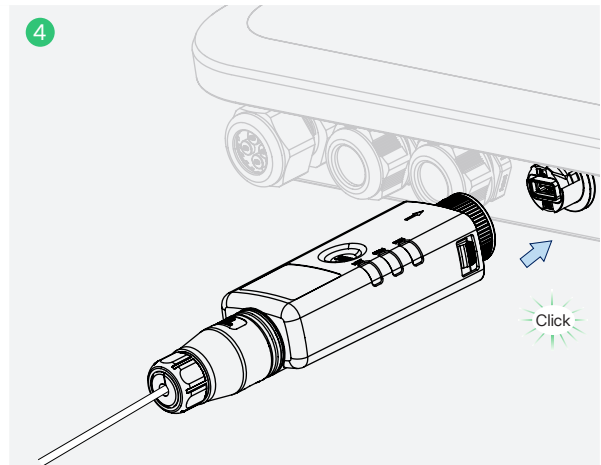
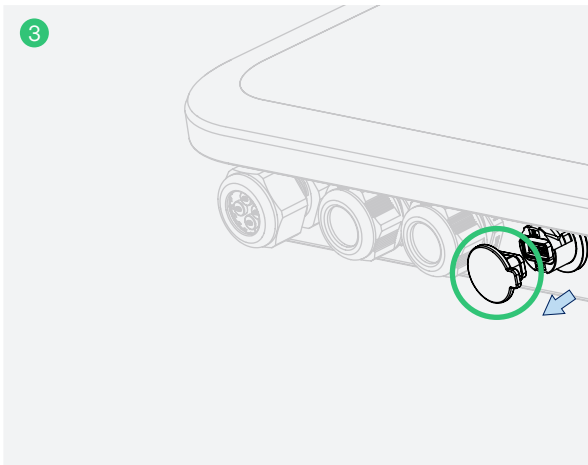

8 System Commissioning

8.1 Preparation

Before the commissioning of the product, make sure:

- The inverter DC switch and external circuit breaker are disconnected.
- The DIP switch is in the “OFF” state.
- The wiring follows the instructions in [7 Electrical Connection](#).
- The grid voltage is within the permissible range through the multimeter before turning on the AC switch.
- The rubber plugs in the unused terminals are not removed.
- Nothing is left on the top of the product.
- Cables are routed in a safe place or protected against mechanical damage.
- Warning signs and labels are intact.

8.2 System Power-on

Step 1 Turn on the battery power switch and DC breaker if the inverter is connected to the battery.

Step 2 Turn on the AC breaker between the inverter and the grid.

Step 3 Rotate the DC switch to “ON” if the inverter is connected to the PV strings.

Step 4 Verify that the inverter is operating properly by checking the [indicator status](#).

9 S-Miles Cloud

The S-Miles App has been developed for Hoymiles and offers the following features.

- Network configuration
- Local installation assistant
- System monitoring



Please download the S-Miles App from the Google Play Store or the App Store, or by scanning the QR code above.

NOTE

- The DTU mentioned in this manual refers to the DTS (Data Transfer Stick).
- In a residential energy storage system, the DTU displayed in the S-Miles Cloud refers to the DTS (Data Transfer Stick).
- The screenshots shown in this manual are for reference only. Since the App version will be updated periodically, the interface displayed on your screen may differ.
- For more information about S-Miles App, refer to [S-Miles Cloud User Manual \(App\)](#).

9.1 Connect to the DTS

NOTE

The steps about the password are only required for the first connection.

Step 1 Tap **O&M** > **Toolkit**.

Step 2 On the **Via Bluetooth** part, tap the DTS to be connected.

Step 3 Enter the default password **123456** and tap **Confirm**.

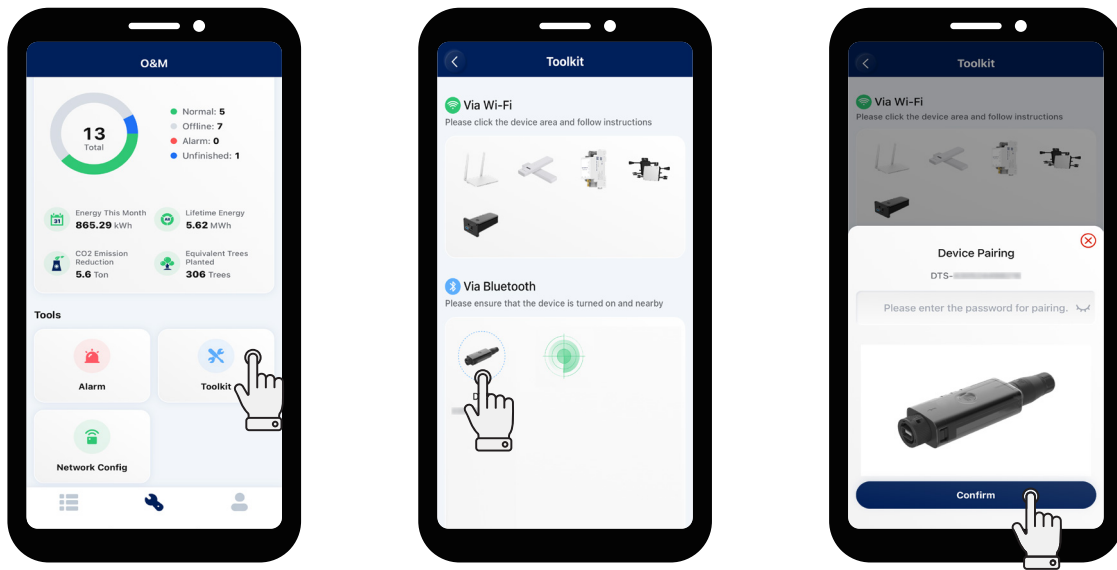

Step 4 Tap **Go to Settings** to change the default password.

Step 5 Enter the original password and new password, confirm the new one, and tap **Send to DTU**.

Step 6 Tap **Toolkit** again.

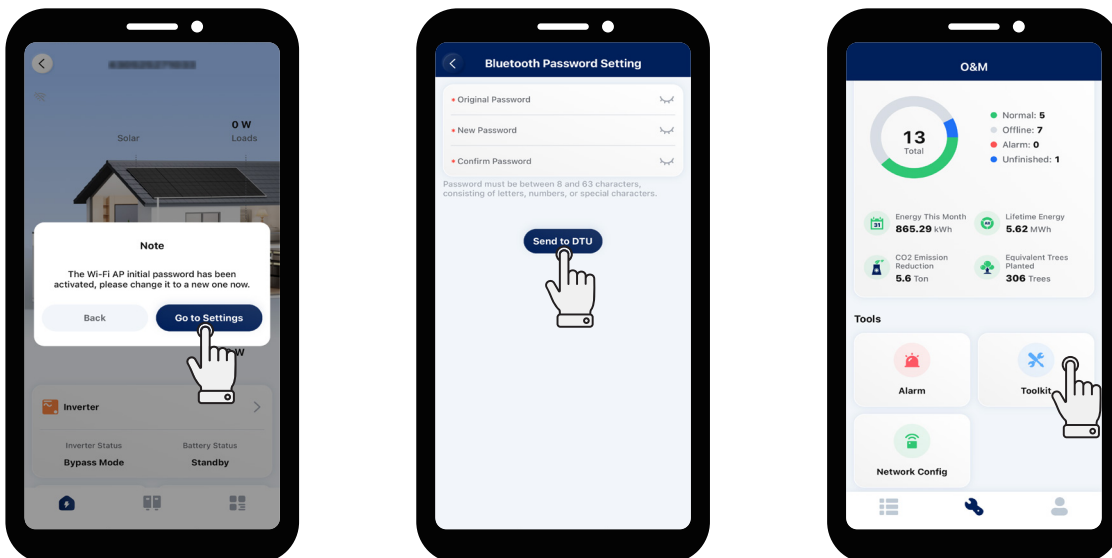

Step 7 On the **Via Bluetooth** part, tap the DTS to be connected.

Step 8 Enter the new password and tap **Confirm**.

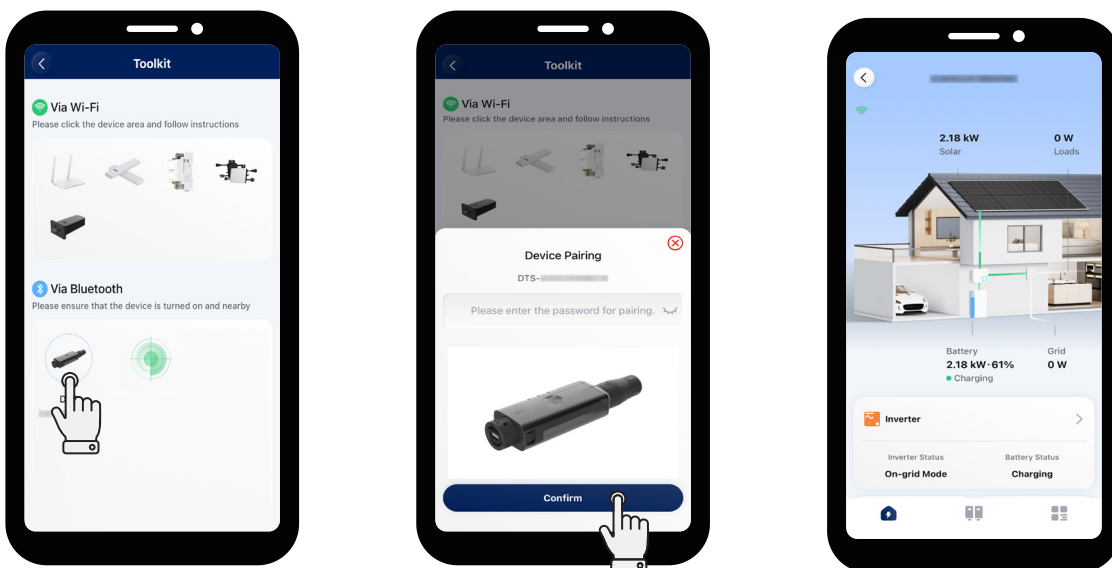

9.2 Start Commissioning

Commissioning is used to set and test a new residential energy storage system. It is a critical step to ensure that a new device and system can function properly according to the design specifications.

Step 1 Tap  **O&M** >  **Toolkit**.

Step 2 Tap  **Commissioning**.

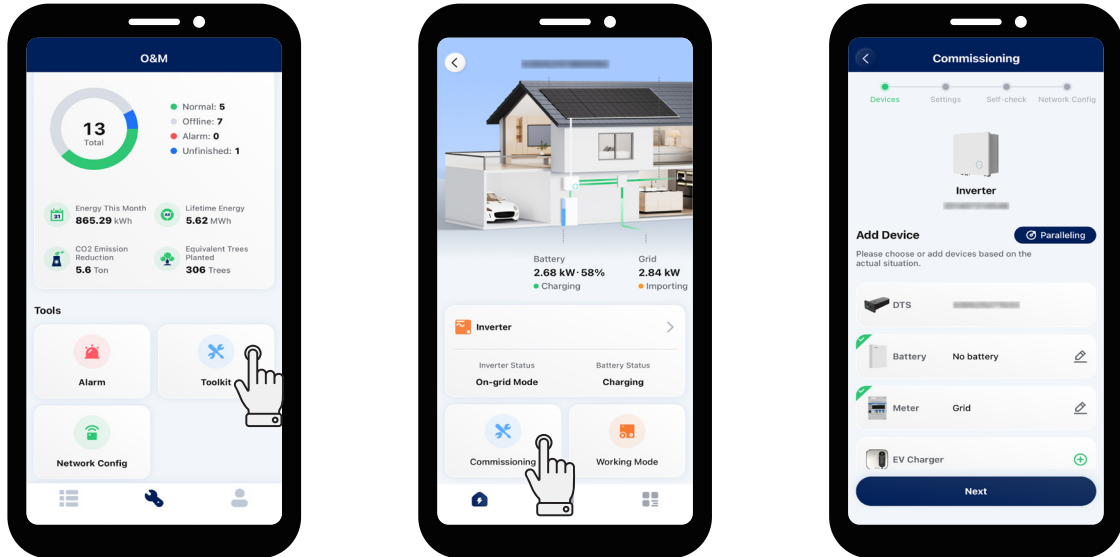

Step 3 Add devices

Follow the instructions below to add devices according to the actual installation, and tap **Next**.

- If a parallel system is installed, tap **Paralleling**. All slave inverters will be automatically added.

NOTE

- The DTS must be connected to the Master.
- After the slaves are connected to the Master through a communication cable, they can communicate with the DTS.
- A DTS can only communicate with up to 10 inverters.

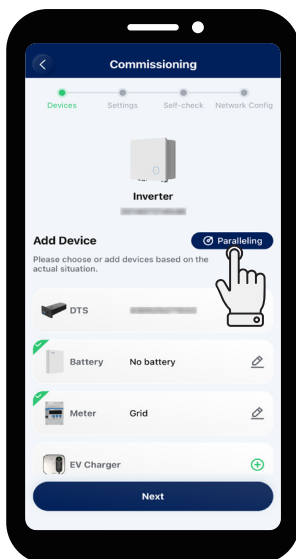

- If batteries are connected to the inverter, tap **Battery** to set the relevant parameters, and tap **Save**. Hoymiles batteries can be automatically identified. (The default battery type is **No battery**.)

NOTE

If Li-ion batteries are connected in parallel via the busbar, and the master battery communicates with the master inverter, enable **Multiple PCS**.

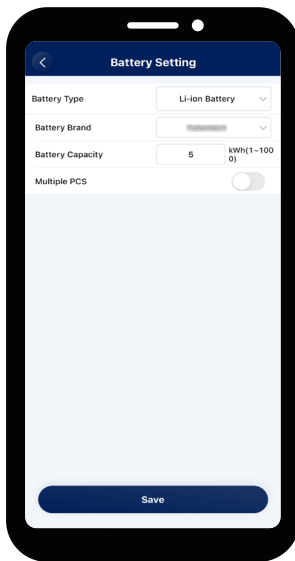
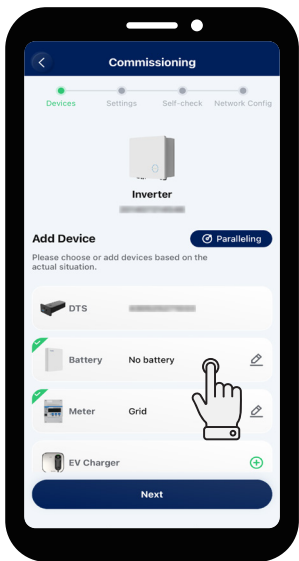

- Tap **Meter** and toggle on **Meter Settings**. Select the meter location based on the actual installation, and tap **Save**.

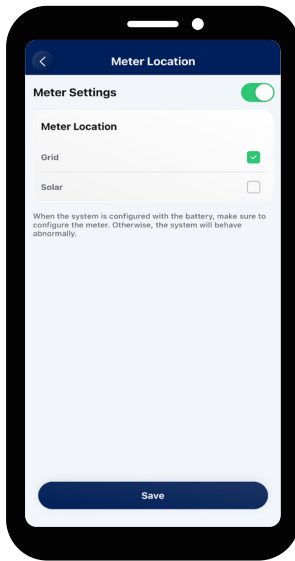
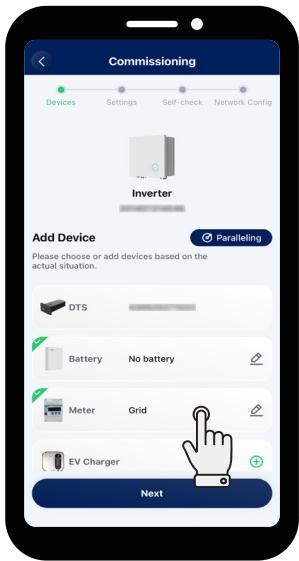

- If an EV charger is connected, tap **EV Charger**. You can tap **Auto Search** or scan the QR code on the label to identify the serial number (SN), and tap **Save**.

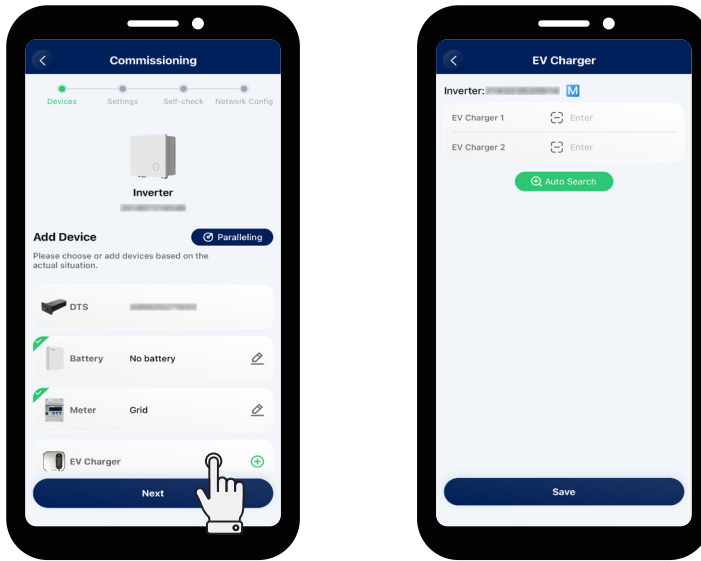

Step 4 Complete other settings

- Select the grid profile in your region, and tap **Next**.
- Select the working mode according to your actual needs, and tap **Next**. For details about working modes, refer to [4.4 Working Modes](#).
- Select **Generator** or **Inverter** according to the actual installation, and tap **Next**. (The default option is **None**.)

NOTE

If a generator is connected to the GEN port, detailed parameters are shown in [9.3.1 Set Advanced Parameters](#). After setting the parameters, tap [System Settings > Dry Contact Settings > Generator Control](#) to set its mode and corresponding parameters.

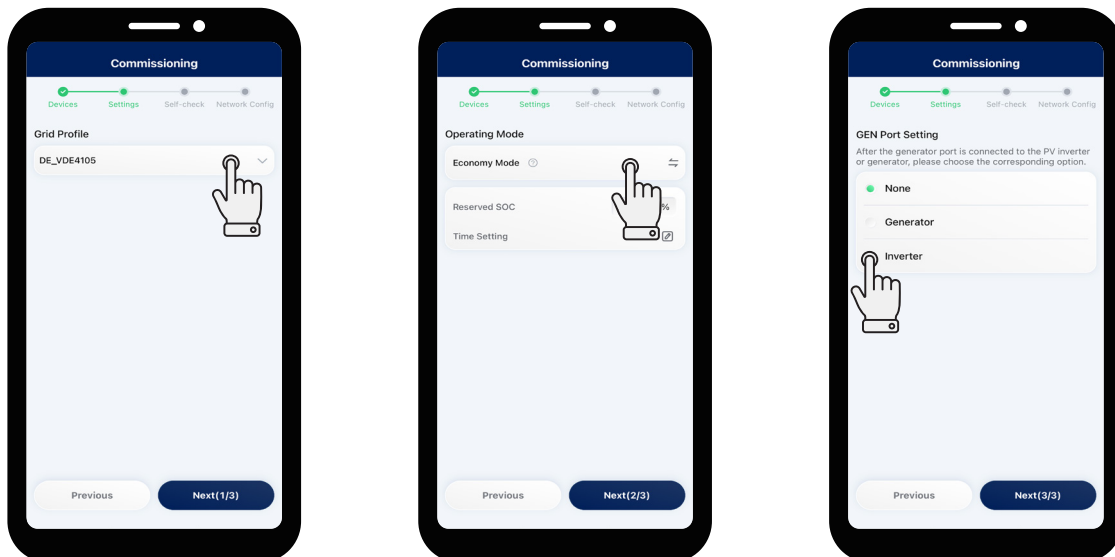

Step 5 Complete the self-check

You can complete or skip the self-check as required.

- If you want to complete the self-check, tap **Start Testing**.

NOTE

- Before this operation, make sure that all cables, including DC cables, AC cables, and communication cables, are properly connected, and all AC and DC switches are turned on.
- If the result shows the CT is reversely connected, tap **Advanced Settings > Grid CT reverse > Enable** or **PV CT reverse > Enable**, and tap **Save**. For details, refer to [9.31 Set Advanced Parameters](#).
- The self-check result is accurate only when the system is connected to the grid.

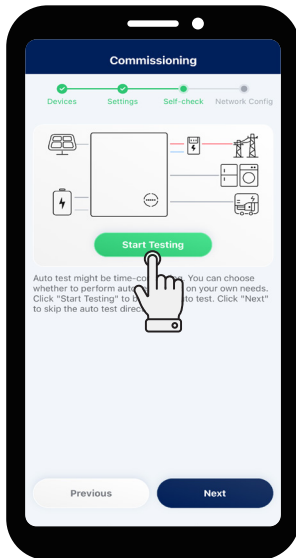

- If you want to skip this step, tap **Next > Confirm**.

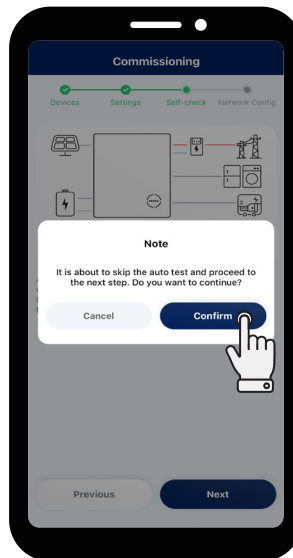
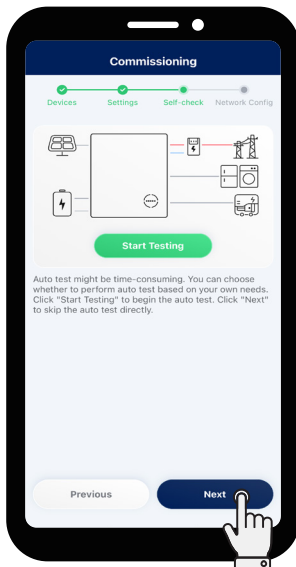

Step 6 Configure the network

NOTE

Go to Settings will navigate to the new plant creation interface (haven't created a plant before the commissioning) or the homepage of the plant (have created a plant before the commissioning).

- Wi-Fi Mode**

- Select **Wi-Fi**, enter or select the Wi-Fi network name, enter the password, and tap **Finish**.
- Tap **Finish** after the network is successfully connected.
- Tap **Stay at Toolkit** or **Go to Settings**.



- LAN Mode**

NOTE

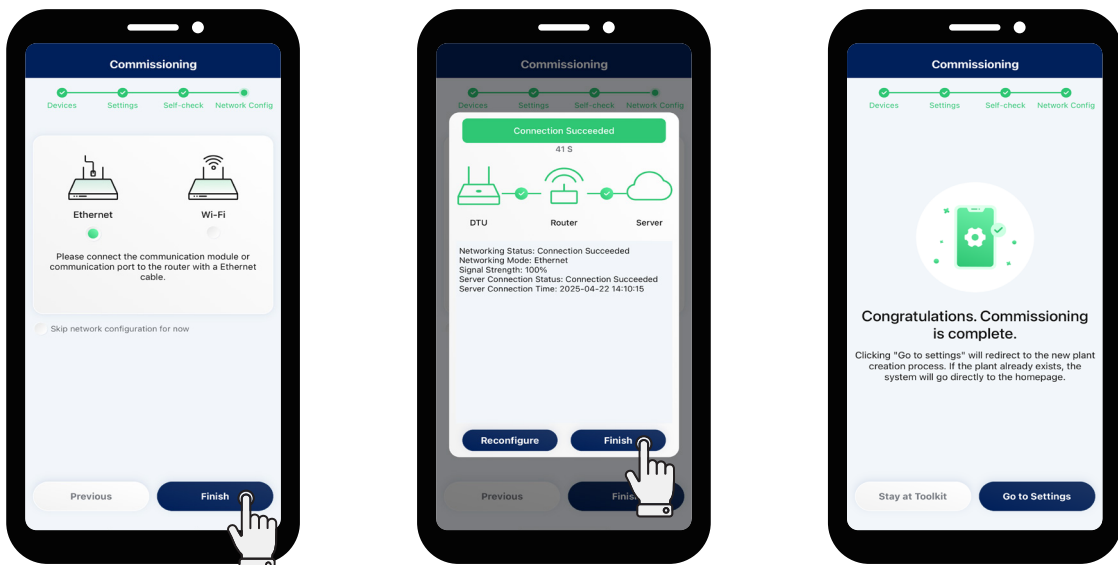

This mode is only applicable to DTS-WL-G3, and the DTS and router are connected via LAN cable.

- Select **Ethernet** and tap **Finish**.
- Tap **Finish** after the network is successfully connected.
- Tap **Stay at Toolkit** or **Go to Settings**.



9.3 Perform System Settings

9.3.1 Set Advanced Parameters

Step 1 Tap  **O&M** >  **Toolkit**, and tap  in the lower right corner.

Step 2 Tap  **Advanced Settings** to set parameters of System, Battery, PV, Emergency Power Supply (EPS), and Generator, and tap **Save**.

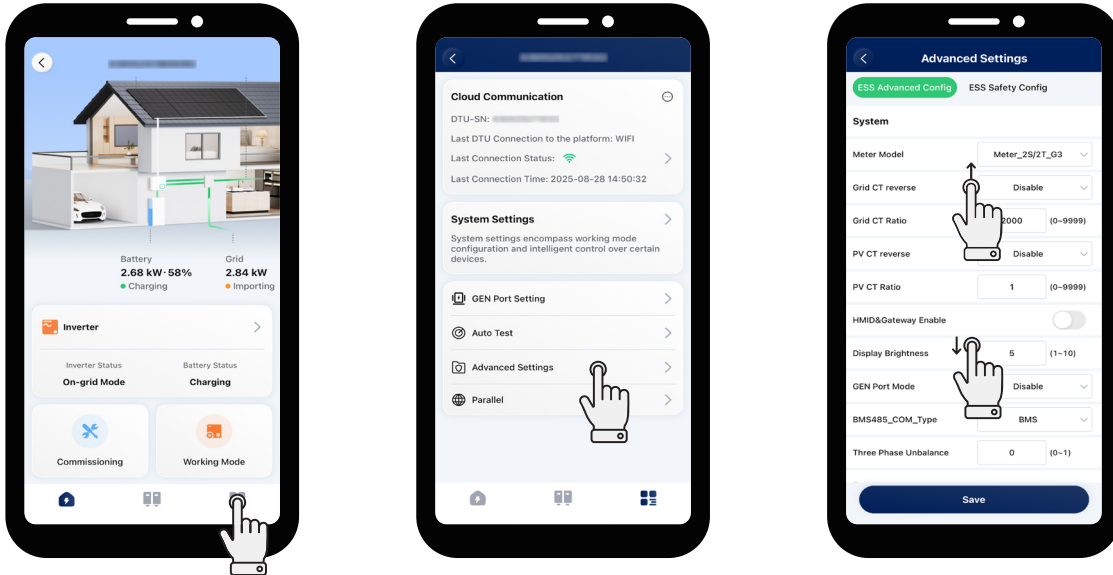

★ System

Parameter	Description	Default Value
Meter Model	<ul style="list-style-type: none"> For a single-phase inverter, select "Single-phase Meter", "Three-phase Meter", "Meter_1S/1T_G3", "Meter_2S/2T_G3", or "CT (Only G3)" according to actual installation. For a three-phase inverter, select "Three-phase Meter", "Meter_1S/1T_G3", "Meter_2S/2T_G3", or "CT (Only G3)" according to the actual installation. 	No Meter
Grid CT Reverse	Enable it to get the correct sampling current when the grid side CT is reversely connected.	Disable
Grid CT Ratio	Set the grid side CT ratio.	2000
PV CT Reverse	Enable it to get the correct sampling current when the PV inverter side CT is reversely connected.	Disable
PV CT Ratio	Set the PV inverter side CT ratio.	2000
Display Brightness	Set the brightness of LED indicators.	10
GEN Port Mode	Select "PV", "Generator", or "Smart Load (Only G3)" based on the actual installation.	Disable
BMS485_COM_Type	<ul style="list-style-type: none"> If the RS485 port is connected to the battery, please select "BMS". If the RS485 port is connected to the microinverter DTU, please select "DTU Com". 	BMS
Three-phase Unbalance	When the loads of the three-phase inverter are not balanced, enable the three-phase unbalance function. It can compensate for each load.	0

★ Battery

Parameter	Description	Default Value
Max. Discharging Power	Set the maximum discharging power.	100%
Max. Charging Power	Set the maximum charging power.	100%
Max. SOC	Set the maximum battery capacity as recommended by the battery manufacturer.	100%
Min. SOC	Set the minimum battery capacity as recommended by the battery manufacturer.	10%
Min. SOC Force Charging Power	Set the power to forcibly charge the battery when the battery SOC falls below the set minimum SOC.	200 W
Reserved SOC Force Charging Power	Set the power to charge the battery when the battery SOC falls below reserved SOC.	2%
Max. BAT Feed-in Power in Peak Time	Set the maximum value of battery feed-in power in peak time.	100%
Max. Grid Charging Power in Off-peak Time	Set the maximum power to charge the battery from the grid in off-peak time.	0 W
Max. BAT Discharging Power in Partial Peak Time	Set the maximum value of battery discharging power in partial peak time.	100%

★ PV

Parameter	Description	Default Value
MPPT Global Scan	If the PV modules are shaded, enable this function.	Disable

★ Emergency Power Supply (EPS)

Parameter	Description	Default Value
EPS Mode	<ul style="list-style-type: none"> When the EPS port is connected, you can select "EPS" or "UPS". You can select "UPS" when the load keeps power on, and the system will automatically switch between the on-grid mode and the off-grid mode under UPS mode. EPS is characterized by a continuous power supply, which means that the loads are powered by bypass under normal power supply, and the DC power will be inverted to supply the loads during a power outage, maximizing energy utilization. UPS (Uninterruptible Power Supply) provides stable voltage and frequency, with extremely strict requirements for switching time. UPS not only operates during power outage, but also can output high quality power supply to ensure normal operation of electric equipment in case of abnormal situations such as overvoltage, undervoltage, and surge. When the inverter is used as a PV inverter, select "Disable". 	EPS

Parameter	Description	Default Value
External Bypass	For inverters with an external ATS (EPS) Box, when the external bypass switch is enabled, the inverter EPS port works in the off-grid mode and will not work in the on-grid mode.	Disable
PV Only	In off-grid mode, the hybrid inverter supports operation with PV when there is no battery connection. (This function is not recommended since the system is unstable under this mode.)	Disable

★ Generator

Parameter	Range
GEN Location	None/GenSide. To ensure the normal operation of the generator, please select "GenSide".
GEN Signal Setting	Manual or DI/DO. If the generator cannot be controlled by dry contact, please select "Manual". If the generator can be controlled by dry contact, please select "DI/DO".
Min. Run Time	5-60 min
Max. Run Time	6-10 hour
Protection Interval	5-60 min
Synchronize Time	1-20 min
Shutdown Delay	1-20 min
GEN Rated Power	0-20000 W
High Voltage Limit	0-280 V
Low Voltage Limit	0-180 V
High Frequency Limit	0-70 Hz
Low Frequency Limit	0-59 Hz
Max. GEN Charging Power	0-20000 W

9.3.2 Enable DRM Function

Step 1 Tap **O&M** > **Toolkit**, and tap  in the lower right corner.

Step 2 Tap **Advanced Settings** > **ESS Safety Config**.

Step 3 Select the grid profile in your region and toggle on **DRM Function Activated**.

Step 4 (For some countries) Set the mode of **DRM Control**.

Step 5 Tap **Save**.

NOTE

- Only the installer can modify grid protection and power quality response mode parameters.
- **DRM Control** for Austria

Zero Export (NO): If the contactor is closed, the feed-in power of the inverter will be limited to zero; if the contactor is disconnected, the inverter will work normally.

Zero Export (NC): If the contactor is closed, the inverter will work normally; if the contactor is disconnected, the feed-in power of the inverter will be limited to zero.

Shutdown (NO): If the contactor is closed, the inverter will be shut down; if the contactor is disconnected, the inverter will work normally.

Shutdown (NC): If the contactor is closed, the inverter will work normally; if the contactor is disconnected, the inverter will be shut down.

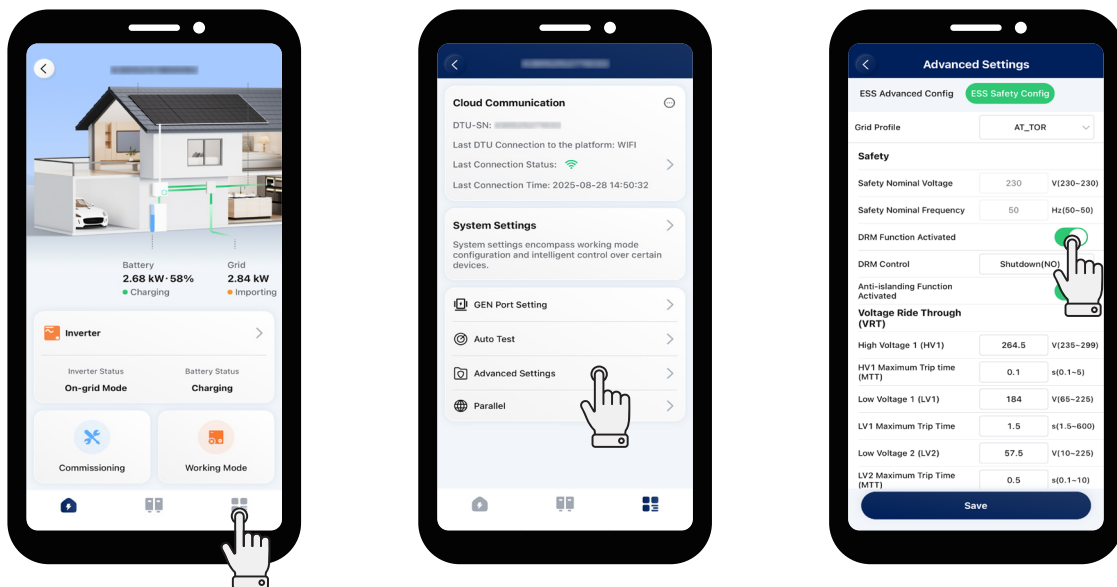

9.3.3 Set Export Management Parameters

NOTE

- This function is enabled by default, and the default value of Max. Export Power Limit is 100%.
 - ESS refers to a single energy storage inverter or a parallel system.
 - The energy storage inverter cannot control the output power of other input devices connected to the grid side. It means that the feed-in power cannot be limited to 0 if other input devices are connected to the grid side.
 - If no input device is connected to the grid side, Max. Export Power Limit can be set to 0-100%.
- If no input device is connected to the grid side, and you do not need to limit the feed-in power, disable this function or skip this setting.
 - If an input device, such as a microinverter, is connected to the grid side, and you do not need to limit the feed-in power, disable this function.
 - If you need to limit the feed-in power, follow the instructions below to set Max. Export Power Limit.

Step 1 Tap **O&M** > **Toolkit**, and tap  in the lower right corner.

Step 2 Tap **Advanced Settings** > **ESS Safety Config**, and slide your finger down to the bottom.

Step 3 Ensure **Generation Control Function (GCF)** is enabled, and set the value of Max. Export Power Limit, and tap **Save**.

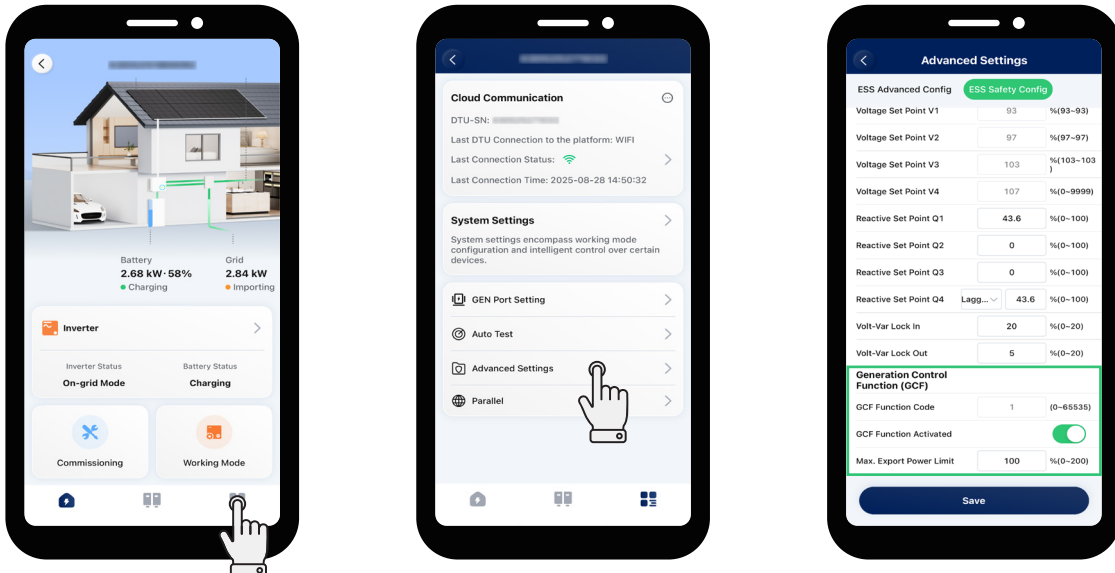

Scenario 1: Max. Export Power Limit is 0

The feed-in power of an Energy Storage System (ESS) is 0. If an input device, such as a microinverter, is connected to the grid side, its output power cannot be controlled; it will output power according to its logic.

Scenario 2: Max. Export Power Limit is 50%

The maximum allowable feed-in power is 50% of the rated power of ESS. If an input device, such as a microinverter, is connected to the grid side, it can operate at full power, and the energy storage inverter will adjust the output of ESS in real time according to the set Max. Export Power Limit.

Scenario 3: Max. Export Power Limit is 100%

The maximum allowable feed-in power is 100% of the rated power of ESS. If an input device, such as a microinverter, is connected to the grid side, it can operate with its full power, and the energy storage inverter will adjust the output of ESS in real time according to the set Max. Export Power Limit.

Scenario 4: Max. Export Power Limit is 150%

The maximum allowable feed-in power is 150% of the rated power of ESS. If an input device, such as a microinverter, is connected to the grid side, it can operate with its full power, and the energy storage inverter will adjust the output of ESS in real time according to the set Max. Export Power Limit.

9.3.4 Set Working Mode

NOTE
Only one mode can be selected at a time.

After the commissioning, if you want to change the working mode, follow the instructions below.

Method One

Step 1 Tap **O&M** > **Toolkit**, and tap **Working Mode**.

Step 2 Select one mode, set relevant parameters, and tap **Save**.

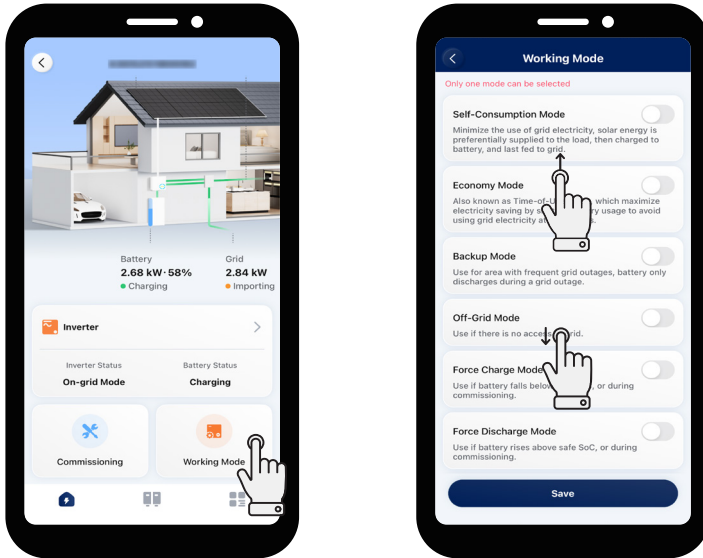

Method Two

Step 1 Tap **O&M** > **Toolkit**, tap **System Settings**.

Step 2 Tap **Working Mode**.

Step 3 Select one mode, set relevant parameters, and tap **Save**.



9.3.5 Set Dry Contact Function

NOTE

Only one mode can be selected at a time.

Step 1 Tap **O&M** > **Toolkit**, tap  in the lower right corner, and tap **System Settings**.

Step 2 Tap  **Dry Contact Settings**.

Step 3 Select one mode, set relevant parameters, and tap **Save**.

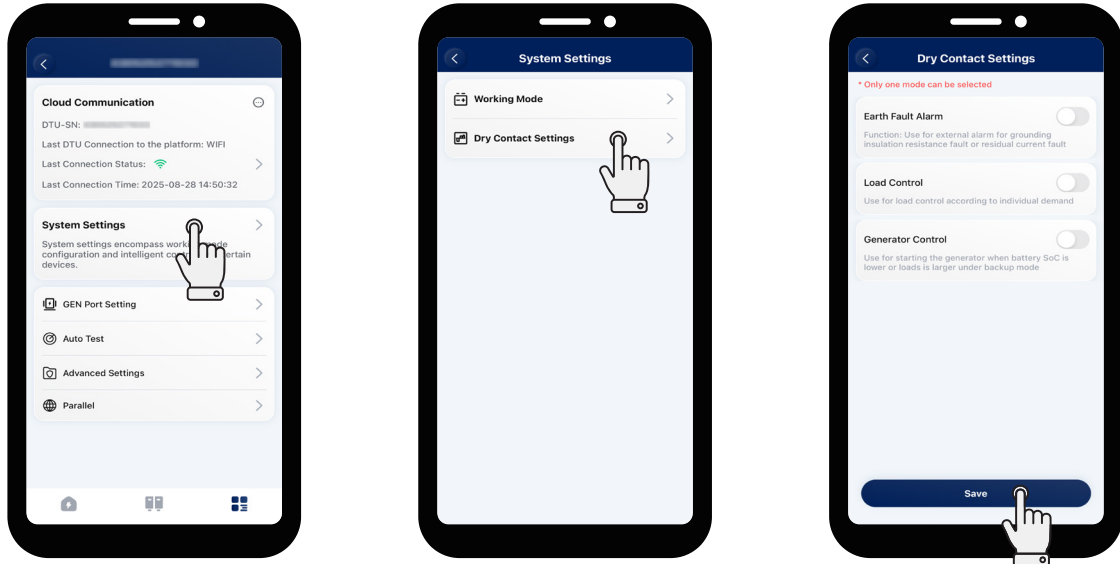

★ Earth Fault Alarm



This function is used for external alarm caused by grounding insulation resistance fault or residual current fault. Disable the external alarm when the load is connected. This function is to produce alarm, not to cause tripping.

★ Load Control

Load control can be used according to individual demand. This setting is to control whether the smart load works or not. There are five modes available as follows.

- **Manual Mode**
The inverter can supply power to the smart load after you select this mode.
- **Scheduled Mode**
Set the time period for the smart load to work. The inverter can supply power to the smart load during this set time, and the smart load will be disconnected at other times.
- **Intelligent Mode**

NOTE

Before selecting the intelligent mode, return to  page, tap  **Advanced Settings**, and set the **Gen Port Mode** to **Smart Load (Only G3)**.

It is necessary to set the value of Min. Running Time and Rated Load Power.

In this mode, the inverter will detect the feed-in power generated by PV in real time. If the feed-in power exceeds the rated load power, the inverter can supply power to the smart load during the pre-set minimum running time. Once the time is up, the inverter will detect the feed-in power again. If the feed-in power is less than the rated load power, the smart load will be disconnected; conversely, the inverter will repeat the above process according to the same logic.

- EPS Port Smart Control

In this mode, battery protection SOC can be set.

In off-grid state, if the battery SOC is higher than the protection SOC, the inverter can supply power to the smart load; if the battery SOC is lower than the protection SOC, the smart load will be disconnected.

- Heat Pump Control (will be coming soon)

The heat pump control function allows users to add up to four runtimes. According to the set power and battery SOC, it can control the start and stop as well as the power of the SG Ready heat pump, maximizing the PV energy utilization.

Parameter	Description
Start Power	When the start power reaches this value, the heat pump control mode is enabled.
Shutdown Power	When the shutdown power reaches this value, the heat pump control mode is disabled.
Battery Starting SOC (Optional)	When the battery SOC reaches this value, the heat pump control mode is enabled.
Battery Shutdown SOC	When the battery SOC reaches this value, the heat pump control mode is disabled.
Min. Single Runtime	When the single runtime reaches this value, the heat pump control mode is disabled.
Max. Single-day Runtime (Optional)	When the running time of the day reaches this value, the heat pump control mode is disabled.
Runtime Settings	Up to 4 operating periods can be set.

★ Generator Control

- Exercise Mode

The generator starts regularly during the preset period to ensure the operation of the generator.

Parameter	Description
Frequency	It allows the generator to start regularly at this frequency.
Start Time	It allows the generator to start regularly at this time.
Duration	The generator will stop running after this duration.

- Running Mode

This mode is the off-grid operation mode of the generator, including manual mode and auto mode.

- ▷ Manual Mode

The manual mode is used to turn on or turn off the generator manually.

- ▷ Auto Mode

The auto mode is used to turn on or turn off the generator according to the battery capacity. The auto mode only supports generators controlled by Dry Contact. Otherwise, please select the manual mode.

Parameter	Description
GEN Start SOC	In off-grid mode, start the generator when the battery capacity is lower than the safety SOC.
GEN Shutdown SOC	In generator mode, shut down the generator when the battery capacity is higher than the safety SOC.
Quiet Time	During the quiet time, the generator is disabled. If you set this time, it will affect the normal use of electricity.

- Battery Charge Time

Parameter	Description
Battery Charge Time	The generator will charge the battery during the preset period. Please choose the time period when the PV power is low to avoid wasting PV power.

9.4 Upgrade the Firmware

NOTE

During the firmware upgrade, do not power off the device.

When you enter the plant overview interface, there will be a pop-up window if there is a new firmware version.

Method One

Step 1 Tap the target plant.

Step 2 Tap **Upgrade**.

Step 3 Tap **Upgrade**.

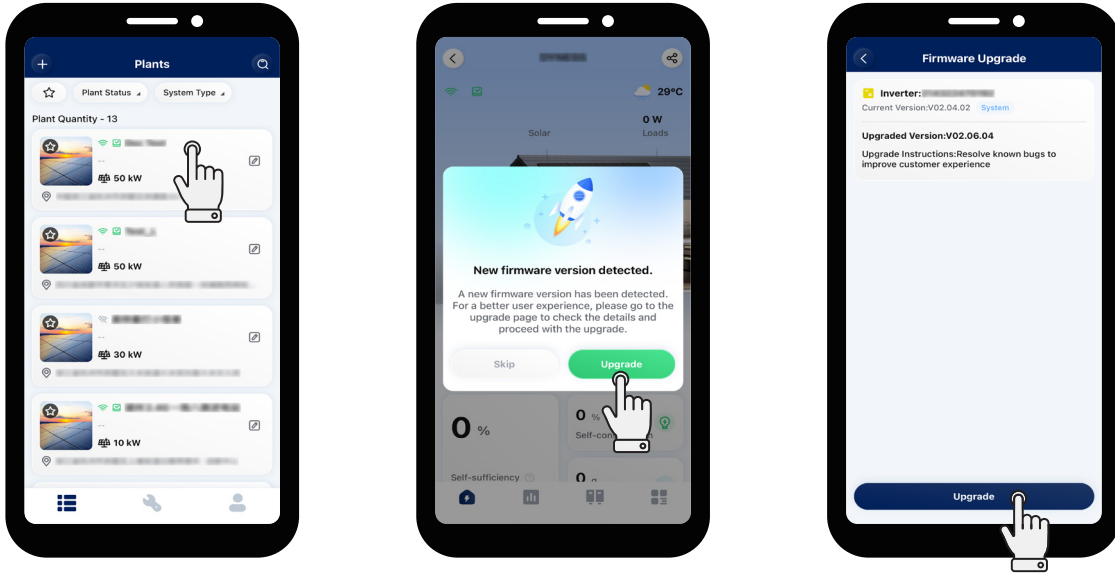

Method Two

If you have tapped **Skip** to perform other operations, you can also follow the instructions below to upgrade the firmware.

Step 1 Tap  in the lower right corner.

Step 2 Tap  **Firmware Upgrade > Upgrade**.

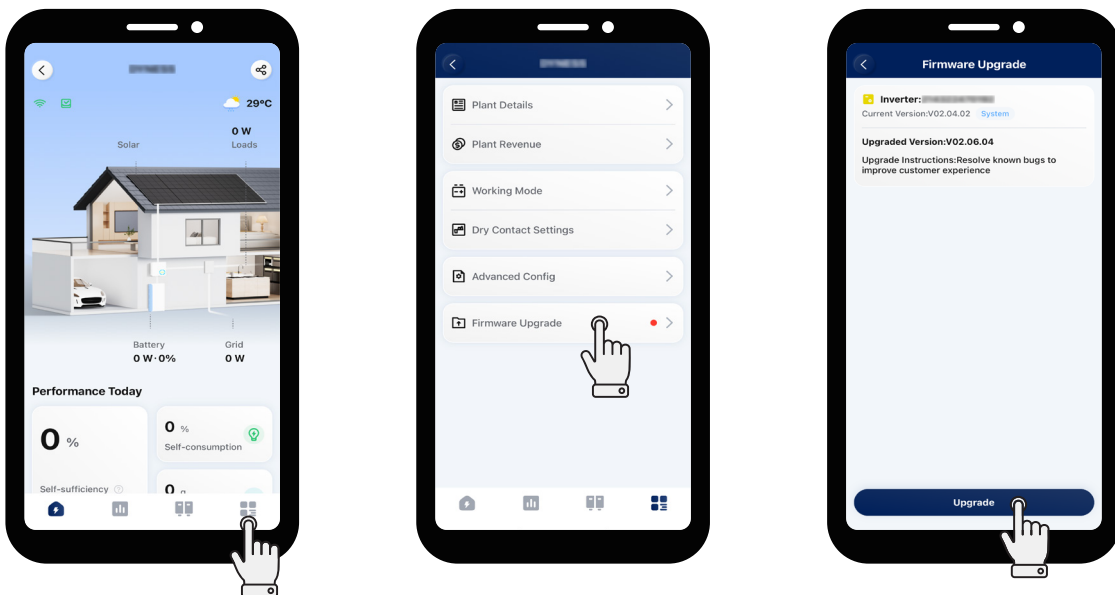

10 System Maintenance

10.1 System Power-off

NOTICE

Wait at least 10 minutes after the LED indicators are off to release the internal energy.

- Step 1** Stop the inverter from working via the S-Miles App.
- Step 2** Disconnect the DC breaker between the inverter and the battery if the inverter is connected to the battery.
- Step 3** Disconnect the AC breaker between the inverter and the grid.
- Step 4** Rotate the DC switch to "OFF" if the inverter is connected to the PV strings.
- Step 5** Check whether the inverter indicators are off.

10.2 Routine Maintenance

To ensure that the inverter can operate for a long time, it is recommended to perform the following maintenance items. Make sure that all maintenance items are performed after the inverter is powered off.

Check Item	Check Method	Maintenance Interval
System Cleanliness	Periodically check the heat sinks to ensure that there are no obstacles and dust.	Once every 6 months
System Operation Status	<ul style="list-style-type: none"> Check whether the inverter is damaged or deformed. Check whether there is an abnormal sound when the inverter is working. Check whether the inverter parameters are set correctly. 	Once every 6 months
Electrical Connection	<ul style="list-style-type: none"> Check whether the cables are firmly connected and intact; in particular, ensure that the parts being contacted with the metal surface are not scratched. Check whether the waterproof plugs or covers of unused ports are firmly in place. 	The first inspection is 3 months after the first installation, and the subsequent inspections can be carried out once every 6 to 12 months.
Grounding Reliability	Check whether the ground cables are firmly connected.	The first inspection is 3 months after the first installation, and the subsequent inspections can be carried out once every 6 to 12 months.

10.3 Troubleshooting

When the system is in alarm, please log in to the S-Miles App to review. The possible causes and their troubleshooting are shown as follows.

Display	Possible Cause	Handling Suggestions
Grid Overvoltage	The grid voltage is higher than the permissible range.	Generally, the inverter will reconnect to the grid after the grid recovers. If the alarm occurs frequently: <ol style="list-style-type: none"> 1. Make sure the ESS safety configuration of the inverter is set correctly. 2. Make sure that the grid voltage in your area is stable and within the normal range. 3. Check whether the cross-sectional area of the AC cable meets the requirement. 4. If the alarm persists, contact Hoymiles technical support team.
Grid Undervoltage	The grid voltage is lower than the permissible range.	Generally, the inverter will reconnect to the grid after the grid recovers. If the alarm occurs frequently: <ol style="list-style-type: none"> 1. Make sure the ESS safety configuration of the inverter is set correctly. 2. Make sure that the grid voltage in your area is stable and within the normal range. 3. Check whether the AC cable is firmly in place. 4. If the alarm persists, contact Hoymiles technical support team.
Grid Overfrequency	The grid frequency is higher than the permissible range.	Generally, the inverter will reconnect to the grid after the grid recovers. If the alarm occurs frequently: <ol style="list-style-type: none"> 1. Make sure the ESS safety configuration of the inverter is set correctly.
Grid Underfrequency	The grid frequency is lower than the permissible range.	<ol style="list-style-type: none"> 2. Make sure that the grid frequency in your area is stable and within the normal range. 3. If the alarm persists, contact Hoymiles technical support team.
No Grid	The inverter detects that there is no grid connected.	Generally, the inverter will reconnect to the grid after the grid recovers. If the alarm occurs frequently: <ol style="list-style-type: none"> 1. Check whether the grid supply is reliable. 2. Check whether the AC cable is firmly in place. 3. Check whether the AC cable is correctly connected. 4. Check whether the AC circuit breaker is disconnected. 5. If the alarm persists, contact Hoymiles technical support team.

Display	Possible Cause	Handling Suggestions
RCD Fault	The residual leakage current is too high.	<ol style="list-style-type: none"> 1. The alarm can be caused by high ambient humidity, and the inverter will reconnect to the grid after the environment is improved. 2. If the environment is normal, check whether the AC and DC cables are well insulated. 3. If the alarm persists, contact Hoymiles technical support team.
PV Reverse Connection	The inverter detects that the PV strings are reversely connected.	<ol style="list-style-type: none"> 1. Check whether the corresponding string is of reverse polarity. If so, disconnect the DC switch and adjust the polarity when the string current drops below 0.5 A. 2. If the alarm persists, contact Hoymiles technical support team.
PV Undervoltage	The PV voltage is lower than the permissible range.	<ol style="list-style-type: none"> 1. Check whether the DC cable is firmly in place. 2. Check whether there is a PV module shaded. If so, remove the shade and ensure the PV module is clean. 3. Check whether the PV module is in abnormal aging. 4. If the alarm persists, contact Hoymiles technical support team.
PV Overvoltage	The PV voltage is higher than the permissible range.	<ol style="list-style-type: none"> 1. Check the specification and numbers of corresponding string PV modules. 2. If the alarm persists, contact Hoymiles technical support team.
Over Temperature	The temperature inside the inverter is higher than the permissible range.	<ol style="list-style-type: none"> 1. Make sure that the installation complies with the instructions from the User Manual. 2. Check whether the alarm "Fan Fault" occurs. If so, replace the faulty fan. 3. If the alarm persists, contact Hoymiles technical support team.
ISO Fault	The insulation impedance of the PV string to the ground is too low.	<ol style="list-style-type: none"> 1. Use a multimeter to determine if the resistance between the earth and the inverter frame is close to zero. If not, please ensure that the connection is good. 2. If the humidity is too high, an isolation fault may occur. Attempt to restart the inverter. If the fault persists, check it again when the weather turns fine. 3. Check the resistance to ground from the PV module/cable. Take corrective measures in case of leading to a short circuit or damaged insulation layer. 4. If the alarm persists, contact Hoymiles technical support team.

Display	Possible Cause	Handling Suggestions
Arc Fault	The inverter detects that there is an arc fault.	<ol style="list-style-type: none"> 1. Disconnect the DC switch and check whether DC cables are damaged and whether the wiring terminals are loose or in poor contact. If so, take corresponding corrective measures. 2. After taking corresponding measures, reconnect the DC switch. 3. If the alarm persists, contact Hoymiles technical support team.
EPS Load Overpower	The EPS load power is higher than the permissible range.	<ol style="list-style-type: none"> 1. Reduce the power of EPS loads, or remove some EPS loads. The inverter will restart automatically. 2. If the alarm persists, contact Hoymiles technical support team.
Meter Reverse Connection	The inverter detects that the Meter or CT is reversely connected.	<ol style="list-style-type: none"> 1. Make sure that the installation complies with the instructions from the User Manual. 2. If the alarm persists, contact Hoymiles technical support team.
Meter Communication Fault	The inverter detects that there is a meter communication fault.	<ol style="list-style-type: none"> 1. Check whether the Meter communication cable and terminal are abnormal. 2. Reconnect the Meter communication cable. 3. If the alarm persists, contact Hoymiles technical support team.
Battery Reverse Connection	The inverter detects that the battery wirings are reversely connected.	<ol style="list-style-type: none"> 1. Check the battery for polarity correctness, and correct it if necessary. 2. If the alarm persists, contact Hoymiles technical support team.
Battery Voltage Fault	The battery voltage is higher than the permissible range.	<ol style="list-style-type: none"> 1. Check if the battery input voltage is within the normal range. 2. If the alarm persists, contact Hoymiles technical support team.
BMS Communication Fault	The inverter detects that there is a BMS communication fault.	<ol style="list-style-type: none"> 1. Check whether the BMS communication cable and terminal are abnormal. 2. Reconnect the BMS communication cable. 3. If the alarm persists, contact Hoymiles technical support team.
BMS Battery Alarm	The inverter detects that there is a battery fault from BMS.	Try to restart the battery. If the fault persists, contact the battery manufacturer.
BMS Battery Fault	The inverter detects that there is a battery fault from BMS.	Try to restart the battery. If the fault persists, contact the battery manufacturer.
Relay Self-check Fault	The inverter detects that there is a relay self-check fault.	Try to restart the inverter. If the fault persists, contact Hoymiles technical support team.

11 Decommissioning

11.1 Removing the Product

Step 1 Power off the product as described in [10.1 System Power-off](#).

Step 2 Disconnect all cables.

Step 3 Remove the DTS and the smart meter.

Step 4 Remove the inverter from the wall and remove the bracket if necessary.

NOTE

Before removing the DTS, first twist it clockwise to unlock the connection between the DTS and the inverter.

11.2 Packing the Product

If the original package is available, put the product and its accessories into the package and keep them in a dry and proper place.

If the original package is not available, put the product and its accessories into a suitable package. The package should be easy to remove, can bear the weight of the product, and can be sealed properly.

11.3 Disposing of the Product

If the product can not be used and needs to be disposed of, dispose of the product and its accessories in accordance with the European Directive 2002/96/EC on Waste Electrical and Electronic Equipment (WEEE).

In accordance with the WEEE and its implementation in national law, the electrical devices must be collected separately and recycled in an environmentally responsible manner. We recommend that you return your used device to your dealer or obtain information regarding a local, authorized collection and disposal system. Failure to comply with this EU Directive may result in a negative impact on the environment.

12 Technical Datasheet

Model	HIS-3L-G3	HIS-3.6L-G3	HIS-4.6L-G3	HIS-5L-G3	HIS-6L-G3
Battery					
Battery type	Li-ion/Lead-acid				
Battery voltage range (V)	40-60				
Max. charging/discharging current (A)	75/75	90/90	115/115	120/120	135/135
Max. charging/discharging power (W)	3000/3150	3600/3800	4600/4850	5000/5250	6000/6300
Charging strategy for Li-ion battery	Self-adaption to BMS				
Charging curve	3 Stages/Equalization				
External temperature sensor	Optional				
Communication	CAN				
PV Input					
Recommended max. PV power (W)	6000	7200	9200	10000	12000
Max. input voltage (V)	550				
Rated voltage (V)	360				
Start-up voltage (V)	100				
MPPT voltage range (V)	90-500				
Max. input current (A)	18/18				
Max. short circuit current (A)	27/27				
MPPT number/Max. input strings number	2/2				
AC Input and Output (On-grid)					
Rated output power (W)	3000	3680	4600	5000	6000
Max. output apparent power (VA)	3300	3680	4600	5500	6600
Max. continuous AC bypass current (A)	50				
Grid form	L/N/PE				
Rated AC output voltage/Range (V)	220/154-264, 230/161-276, 240/168-288				
Rated grid frequency (Hz)	50/60				
Max. output current (A)	15	16.7	20.9	25	30
Power factor	>0.99 (0.8 leading-0.8 lagging)				
AC Output (Backup)					
Rated output power (W)	3000	3680	4600	5000	6000
Max. output apparent power (VA)	6000, 10s	7360, 10s	9200, 10s	10000, 10s	12000, 10s
Back-up switch time (ms)	0				
Grid form	L/N/PE				
Rated output voltage (V)	220/230/240				
Rated output frequency (Hz)	50/60				
Max. continuous output current (A)	13.6	16.7	20.9	22.7	27.3
THDv (@linear load)	<3%				
Efficiency					
MPPT efficiency	99.9%				
Max. efficiency	97.7%				
EU efficiency	97.0%				
Protection					
Anti-islanding protection	Integrated				
PV string input reverse polarity protection	Integrated				
Insulation resistor detection	Integrated				
Residual current monitoring unit	Integrated				
AC overcurrent protection	Integrated				
AC short circuit protection	Integrated				
AC overvoltage and undervoltage protection	Integrated				
Surge protection	DC Type II/AC Type II				
General					
Dimensions (W × H × D [mm])	506 × 495 × 99				
Weight (kg)	17				
Mounting	Wall-mounted				
Operating temperature (°C)	-25 to +65 (>45, derating)				
Relative humidity	0-95%, no condensation				
Cooling	Natural convection				
Topology (Solar / Battery)	Transformerless/High-frequency isolation				
Altitude (m)	≤4000				
Protection degree	IP66				
Noise (dB)	<35				
User interface	LED, App				
Digital input/output	DRM, 2 × DI, 2 × DO				
Communication	RS485, Wi-Fi/Ethernet/4G (optional)				
Certifications and Standards					
Grid connection standard	G98, G99, G100, EN 50549-1/-10, NF EN 50549-1/-10, CEI 0-21, PEA, MEA, IEC 62116, IEC 61727, IEC 60068, IEC 61683, DEWA				
Safety/EMC standard	IEC 62109-1/-2, EN 61000-6-1/-2/-3/-4				

13 Appendix 1: Application of an AC Coupled System

AC Coupled System Introduction

The HIS-(3-6)L-G3 series inverter is compatible with any grid-connected inverter (PV inverter or microinverter). With the addition of Hoymiles hybrid inverter, the existing PV system can be retrofitted to be a PV Energy Storage System (ESS) allowing more self-consumption energy and more backup energy.

NOTE

- If there is a strong desire to use this system in off-grid mode, it is recommended to connect the PV inverter to the GEN port; if not, it is recommended to connect the PV inverter to the grid port.
- If the PV inverter is connected to the GEN port, the power of the PV inverter shall be less than the rated output power of Hoymiles hybrid inverter.
- If power export management is required, the power of the PV inverter shall be less than the battery charging power. The zero-export function will be disabled after the battery is fully charged.

Working Modes

- On-grid Mode

When the PV power is sufficient, the hybrid inverter and PV inverter will power the common loads and EPS loads together. When there is surplus power on the PV inverter side, the system will also charge the battery. When PV Power is insufficient, the hybrid inverter, PV inverter, and grid will power all loads.

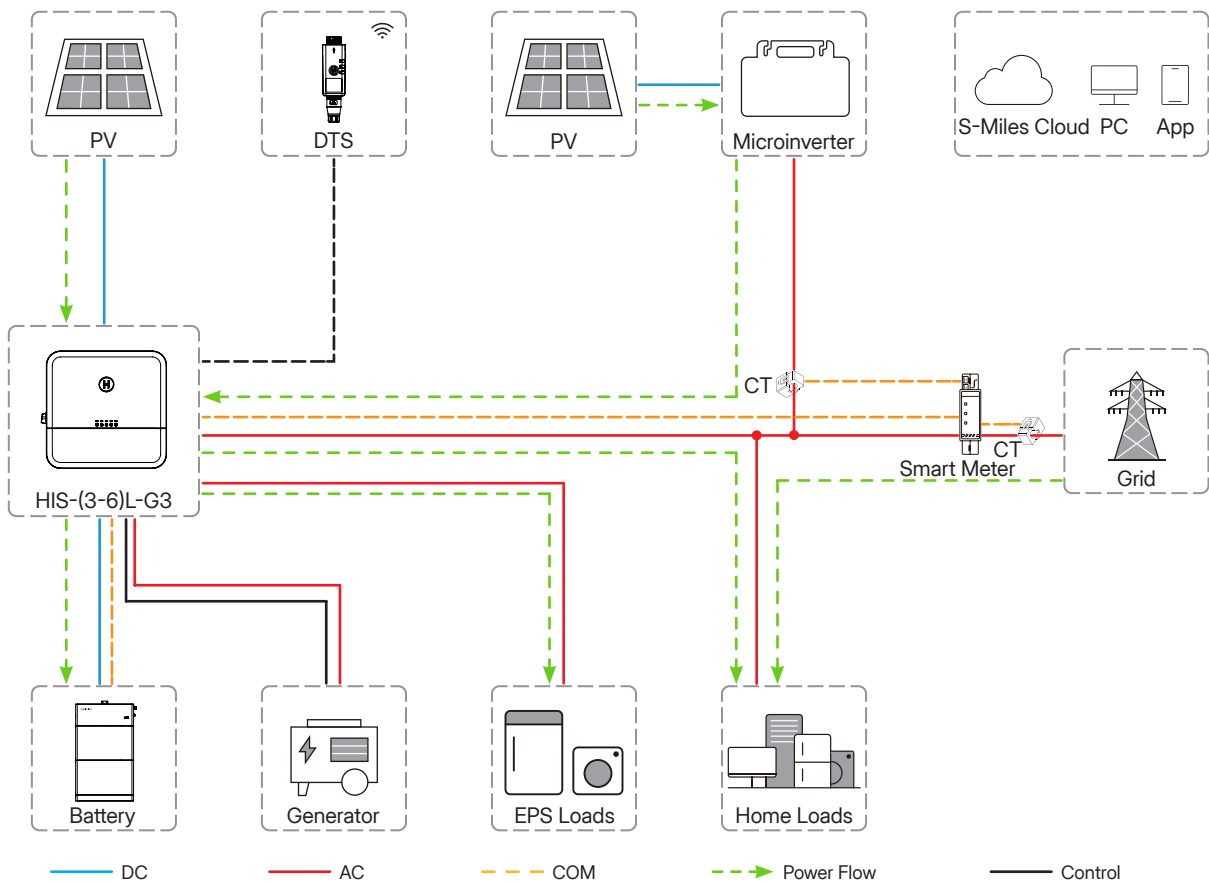

Figure 13-1 On-grid System

- Off-grid Mode

In this mode, the hybrid inverter will simulate the grid so as to make the PV inverter work. The hybrid inverter and the PV inverter will power the EPS loads together. If there is surplus power, the system will charge the battery.

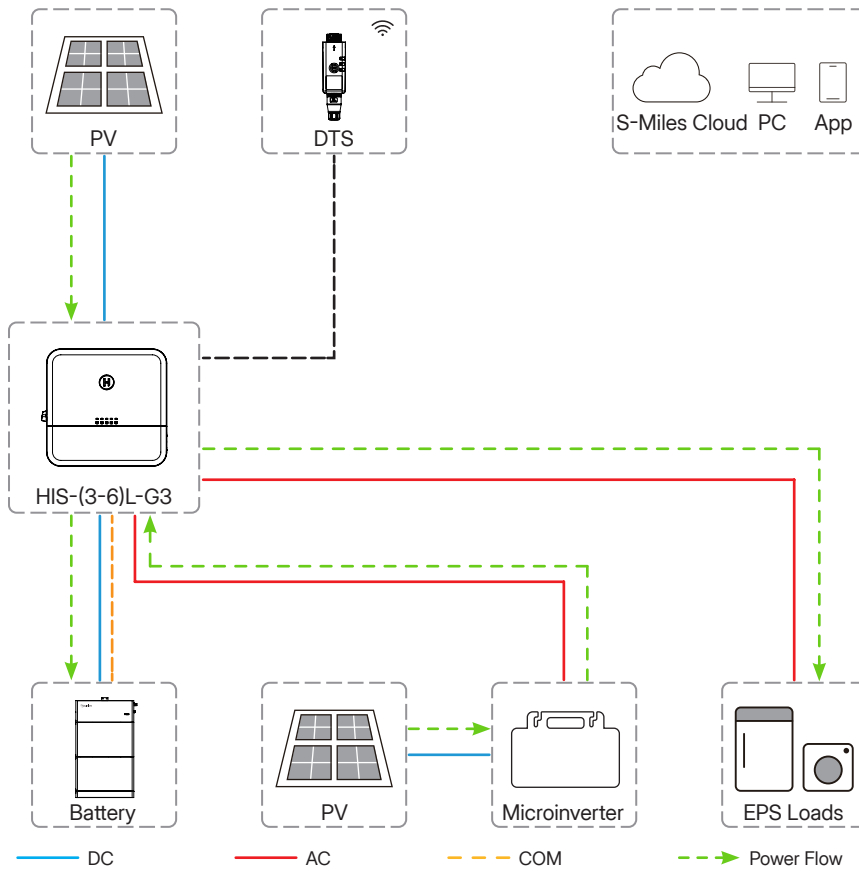

Figure 13-2 Off-Grid System

NOTE

- If the whole system has no power supply, the battery will be charged by the PV power once the PV starts to generate power, and the whole system will restart when the reserved SOC is reached.
- Do not connect the PV inverter and the generator to the GEN port at the same time.

14 Appendix 2: Application of Parallel Function

Parallel Function Introduction

The HIS series inverter supports parallel operation in both on-grid and off-grid modes. In the on-grid mode, the inverter can support up to 10 units in parallel. In off-grid mode, it supports up to two units in parallel without contactors, and can support up to 10 units in parallel when contactors are used.

NOTE

- To optimize the efficiency, it is recommended that all inverters connected in parallel have the same model and the same software version, and are connected to batteries of the same model and quantity.
- By default, the inverter connecting to the meter/DTS is the master, and the meter and DTS must be connected to the same inverter. The overall system works based on the setting parameters of the master.
- The master inverter can control all slave inverter's energy management and dispatch control. Once the master inverter has some errors and stops working, all slave inverters will be stopped simultaneously. But when the slave has some errors, only the system capacity will be reduced, and the master will not be affected.
- The parallel system is extremely complex and requires a large number of cables to be connected. Therefore, the cables must be connected correctly. Otherwise, any small mistake can lead to system failure.
- The master inverter and slave inverters must be connected to the same phase. Connecting the master inverter and slave inverters to L1/L2/L3 separately will cause system errors or damage the devices.

Correct: Master - L1, Slaves - L1

Wrong: Master - L1, Slave 1 - L2, Slave 2 - L3

Communication Connection

Parallel operation is performed through the Parallel_1/Parallel_2 terminals. When inverters are connected in parallel, set the termination resistor. The first and the last inverters are "ON", and the others are "OFF".

NOTE

- For the termination resistor (CAN), if more than eight inverters are connected in parallel, the first inverter, one inverter in the middle, and the last inverter must be set to "ON".
- Ensure that the total length of the cables used for parallel communication does not exceed 20 m.

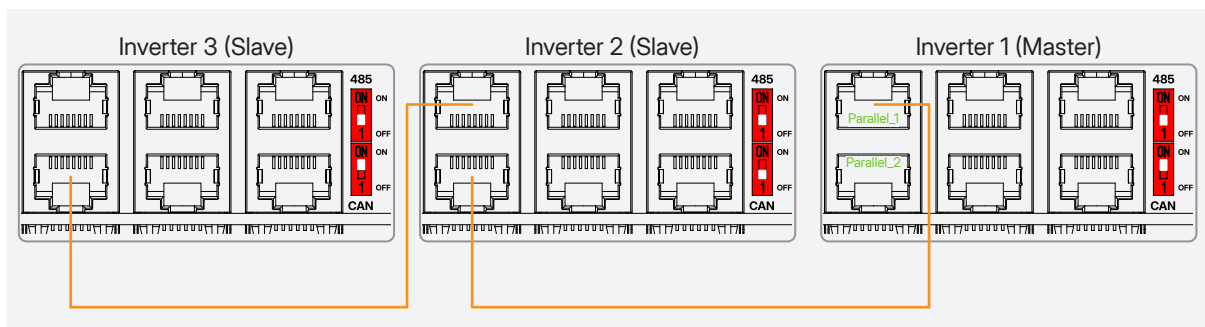

Figure 14-1 Parallel Communication

Contactor Connection

For **Parallel System 3** and **Parallel System 4**, select a normally open contactor, connect it to the DL₂ and DO₂ terminals of the inverter, and connect the auxiliary power supply of the contactor to the grid side. The contactor connection method is shown as follows.

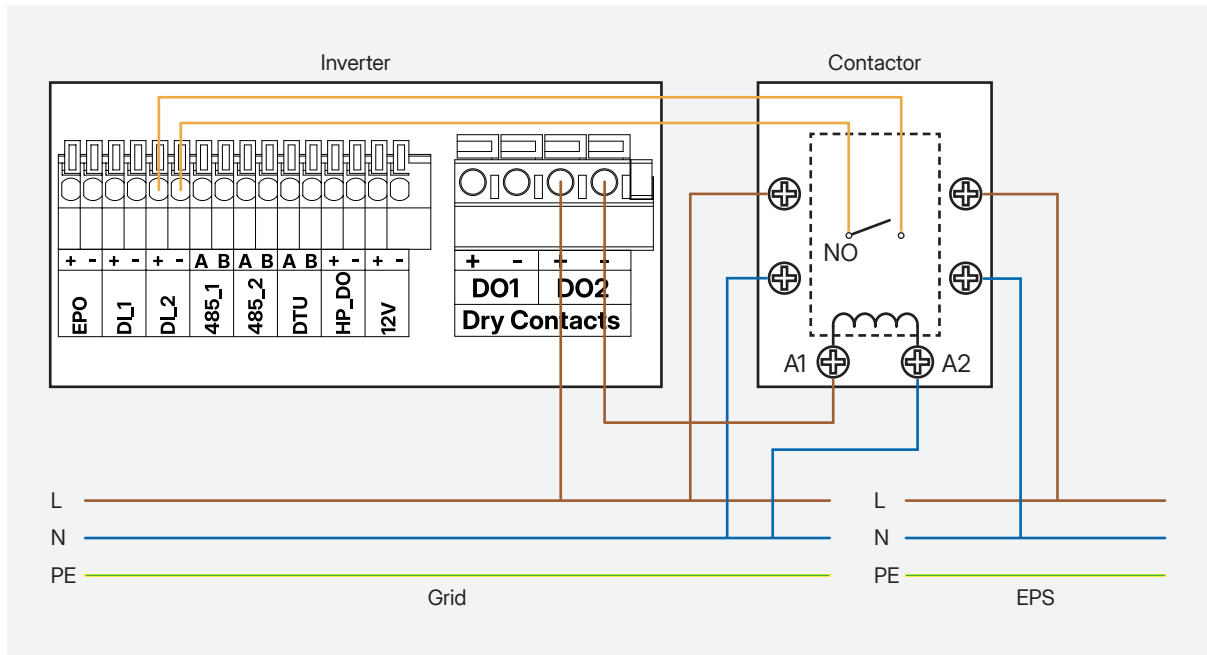

Figure 14-2 Contactor Connection

Recommended Contactor Specifications

Parallel Quantity	3	4	5	6	7	8	9	10
Current (A)	150	200	250	300	350	400	450	500

NOTE
Select the appropriate contactor based on the actual loads.

System Diagram

Please turn to [page 70-73](#).

Online Setting

Refer to [9 S-Miles Cloud](#) or [S-Miles Cloud User Manual \(App\)](#).

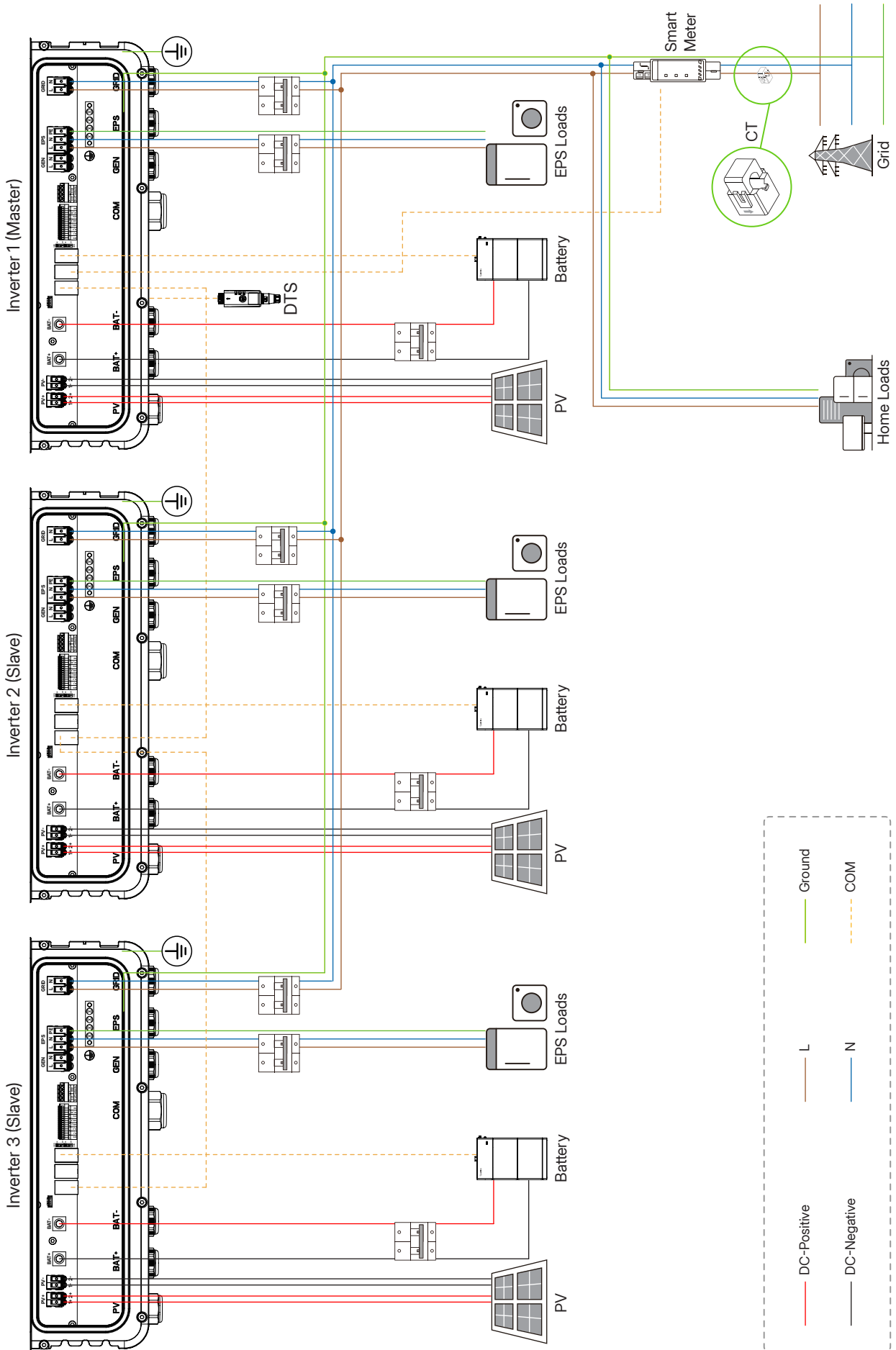

Figure 14-3 Parallel System 1

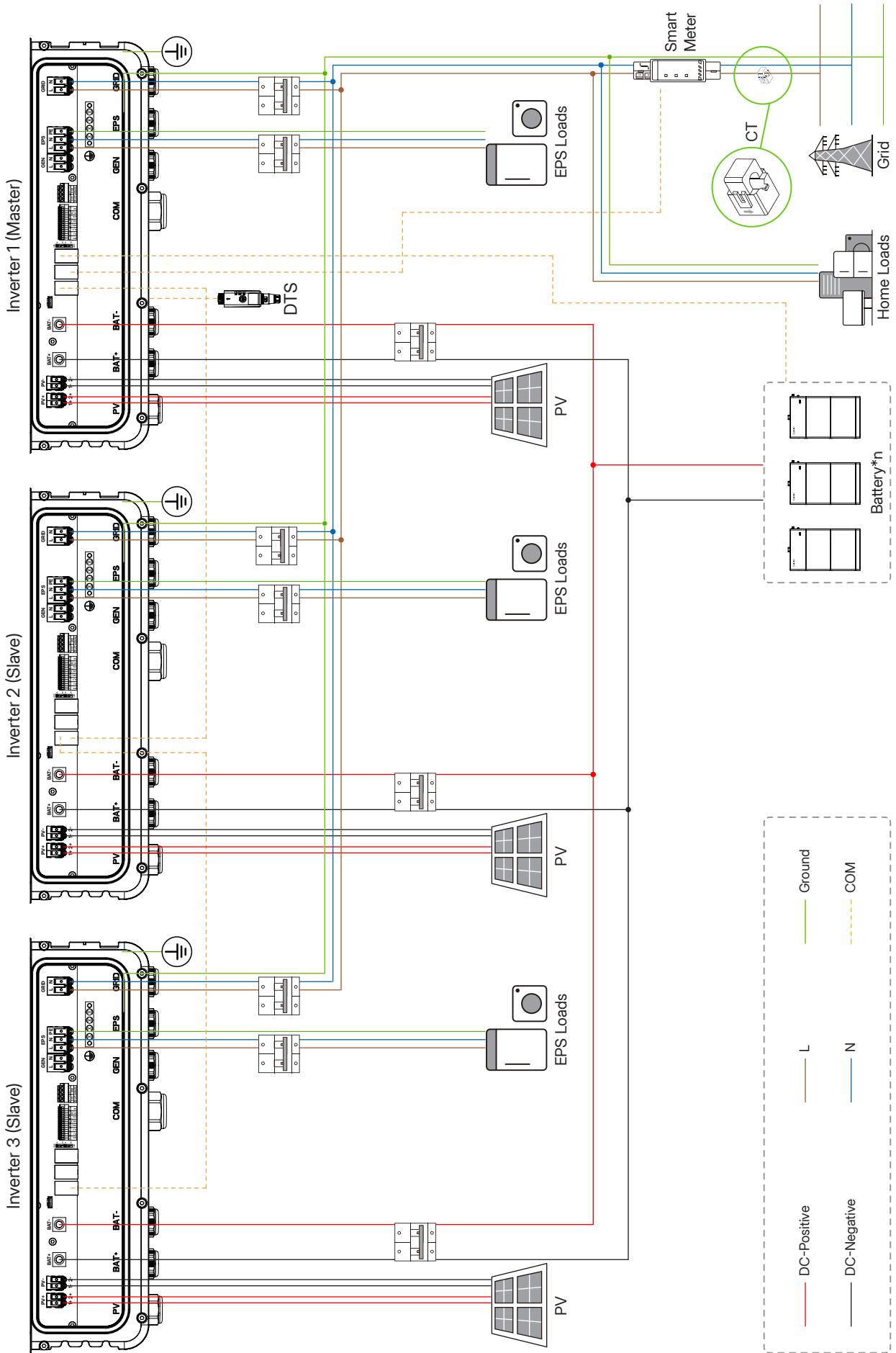

Figure 14-4 Parallel System 2

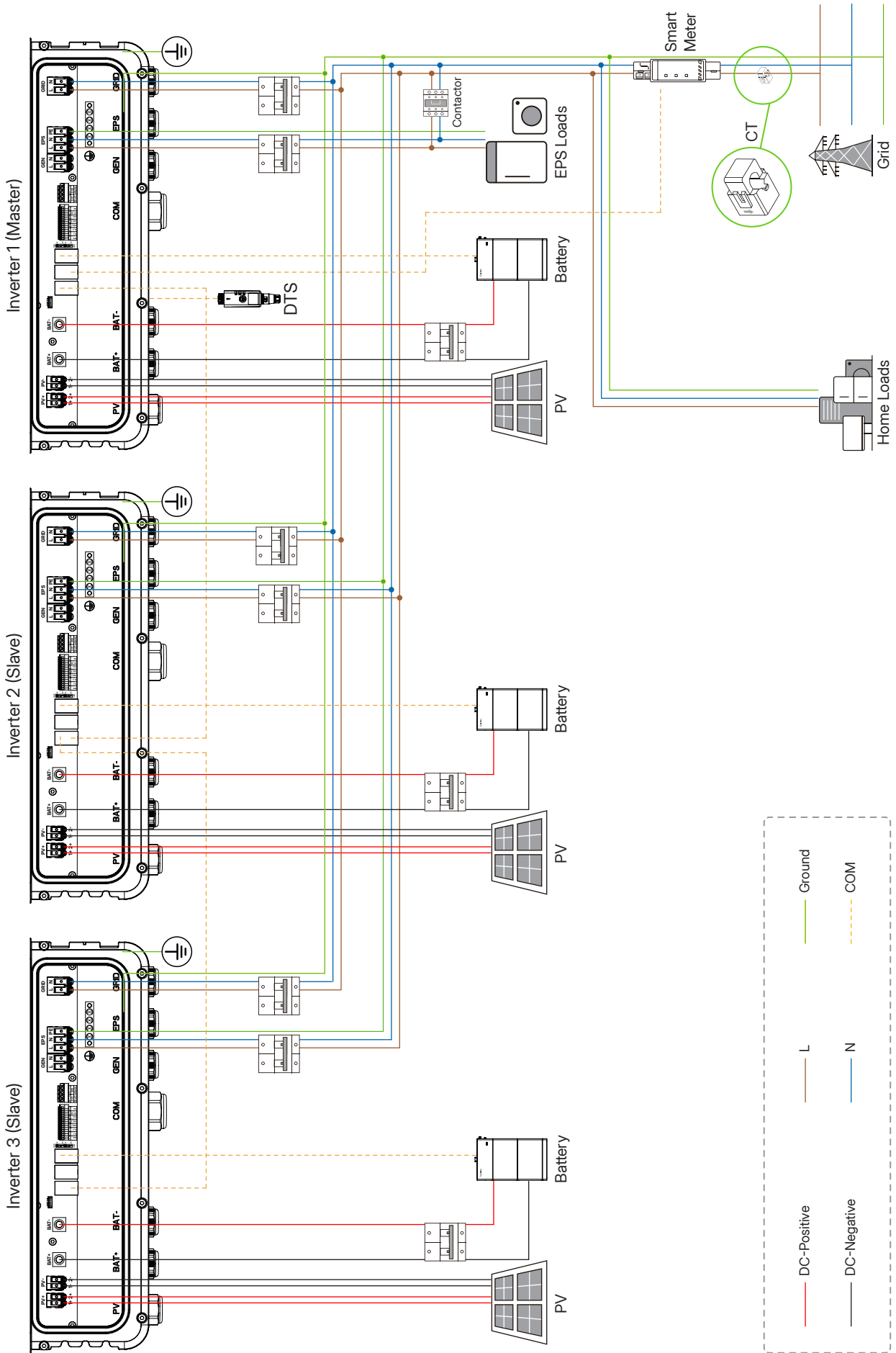

Figure 14-5 Parallel System 3

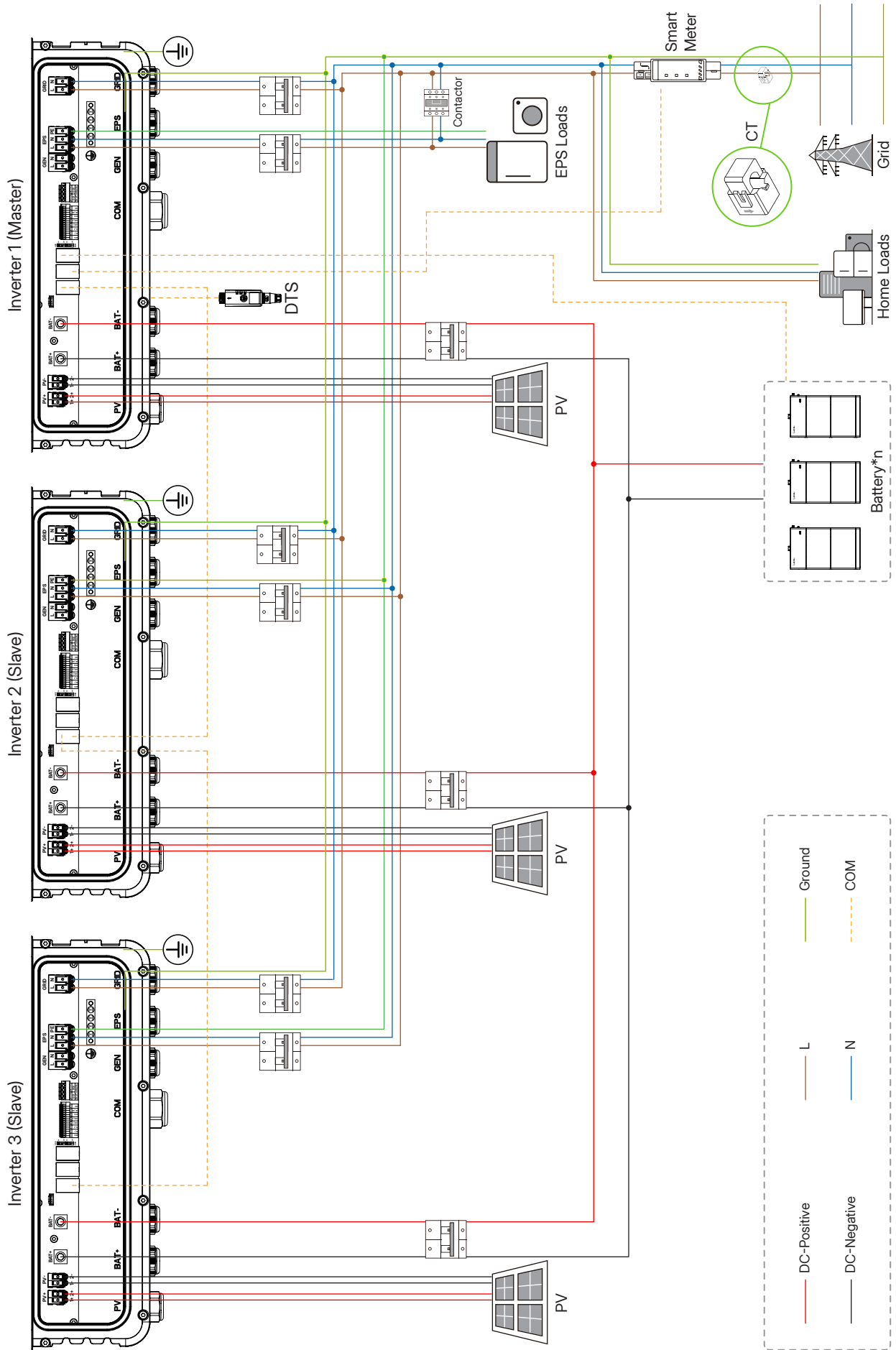

Figure 14-6 Parallel System 4

15 Appendix 3: Application of Lead-acid Battery

Lead-acid Battery Introduction

Because of its wide compatibility, lead-acid batteries are widely used in energy storage system. In backup and off-grid scenarios, it is important that the inverter is compatible with lead-acid batteries. The inverter can convert the DC power stored in lead-acid batteries into AC power. This ensures a stable power supply during grid failures, allowing for the seamless operation of various electrical appliances.

System Diagram

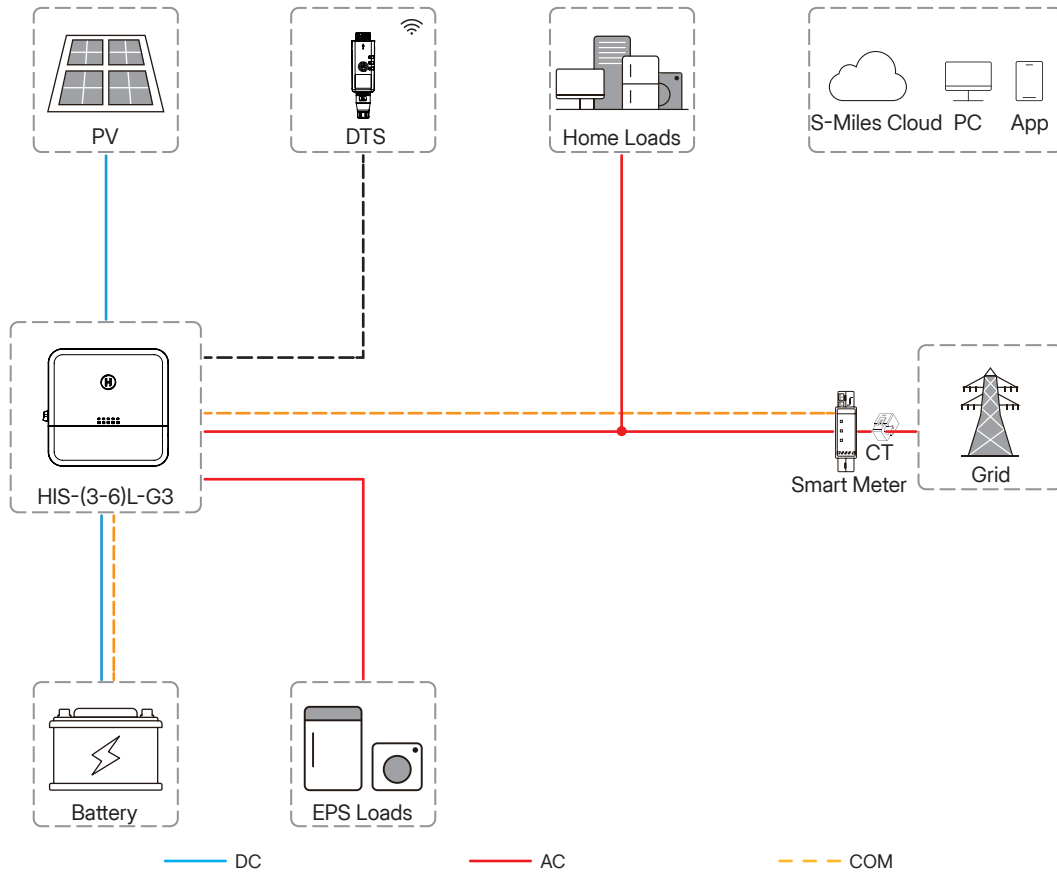

Figure 15-1 Lead-acid Battery System

Temperature Sensor Connection

Connect one end of the temperature sensor to the BMS terminal of the inverter and place another end on the lead-acid battery.

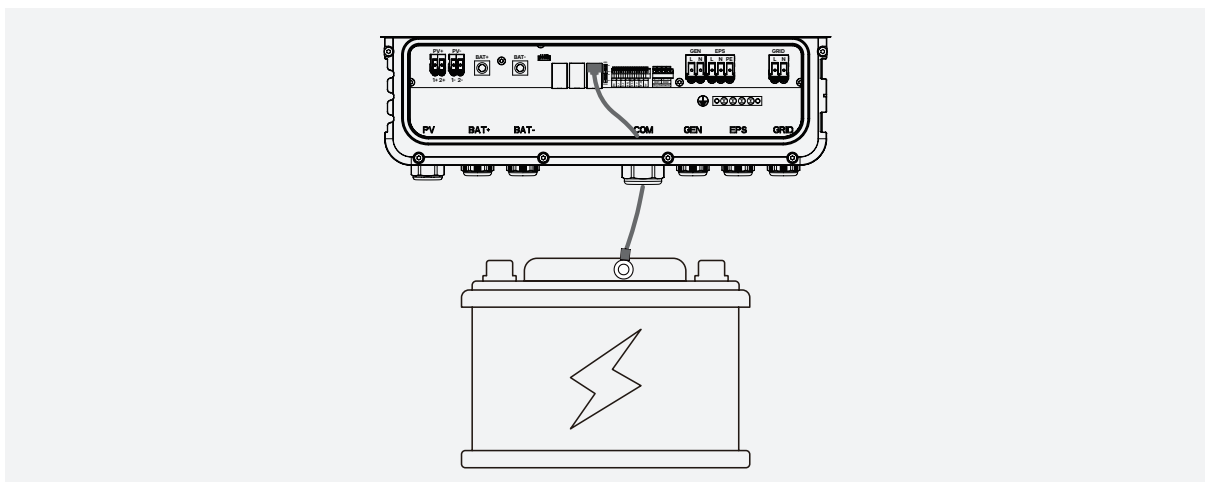

Figure 15-2 Temperature Sensor Connection

Online Setting

Refer to [S-Miles Cloud User Manual \(App\)](#). Detailed parameters are shown as follows.

Parameter	Description
Battery Capacity	It tells the off-grid inverter to know battery capacity.
Max. Charging Current	Set the maximum charging current.
Max. Discharging Current	For AGM and Flooded, we recommend Ah battery size x 20%= Charge Discharge amps. For Gel, follow manufacturer's instructions.
Floating Charge Voltage	The battery will be charged at this voltage to supplement the self-discharge of the battery.
Absorption Voltage	Set the voltage of absorption charging stage.
End of Charge Current	Set the end of charge current. It is recommended to set the default value (0 A).
Temperature Correction Factor	Set the temperature correction factor. It is recommended to set the default value (0 mV/°C/Cell).
Battery Initial Resistance	Set the battery initial resistance. It is recommended to set the default value (30 mΩ).
Equalization	Regularly enable the equalization to improve battery life.
Equalization Voltage	Set the equalization voltage. It is recommended to set the default value (58.8 V).
Equalization Interval Days	The equalization will be regularly enabled according to this set value. It is recommended to set the default value (90 d).
Equalization Time	The duration of each battery equalization cycle. It is recommended to set the default value (120 min).
Equalization Timeout	Set the equalization timeout. It is recommended to set the default value (10 min).

Recommended Battery Voltage Settings

Battery Type	Absorption Voltage	Float Voltage	Equalization Voltage
AGM (or PCC)	14.2 V (57.6 V)	13.4 V (53.6 V)	14.2 V (57.6 V)
Gel	14.1 V (56.4 V)	13.5 V (54.0 V)	/
Wet	14.7 V (59.0 V)	13.7 V (55.0 V)	14.7 V (59.0 V)

NOTE

Please set these values according to your actual needs and battery parameters.

16 Appendix 4: Application of Generator

Generator Function Introduction

In certain regions where utility power is unstable, the use of generators becomes necessary to ensure uninterrupted operation of loads. A generator is employed to replicate grid-like functionality, while the off-grid inverter converts solar energy into usable electric energy.

NOTICE

- The generator can be connected only to the GEN port. Ensure that the generator power is less than the rated power of the inverter.
- In the GEN mode, the inverter works in Self-consumption Mode. When it is allowed to charge the battery, the power generated from PV first supplies the loads, and the surplus PV power can charge the battery.

Working Modes

- Exercise Mode

To ensure the normal operation of the generator, the exercise mode of the generator can be enabled, and the frequency, time, and duration can be set to make the inverter start and stop regularly. The exercise mode and the running mode can be enabled at the same time. The exercise mode is usually enabled when the system is in the on-grid state.

- Running Mode

▷ Manual Mode

In this mode, there is no communication between the generator and the inverter, which means no communication wiring is required. Users need to manually turn on or turn off the generator, and the inverter will determine whether the GEN mode should be turned on or off based on the status of the grid and generator.

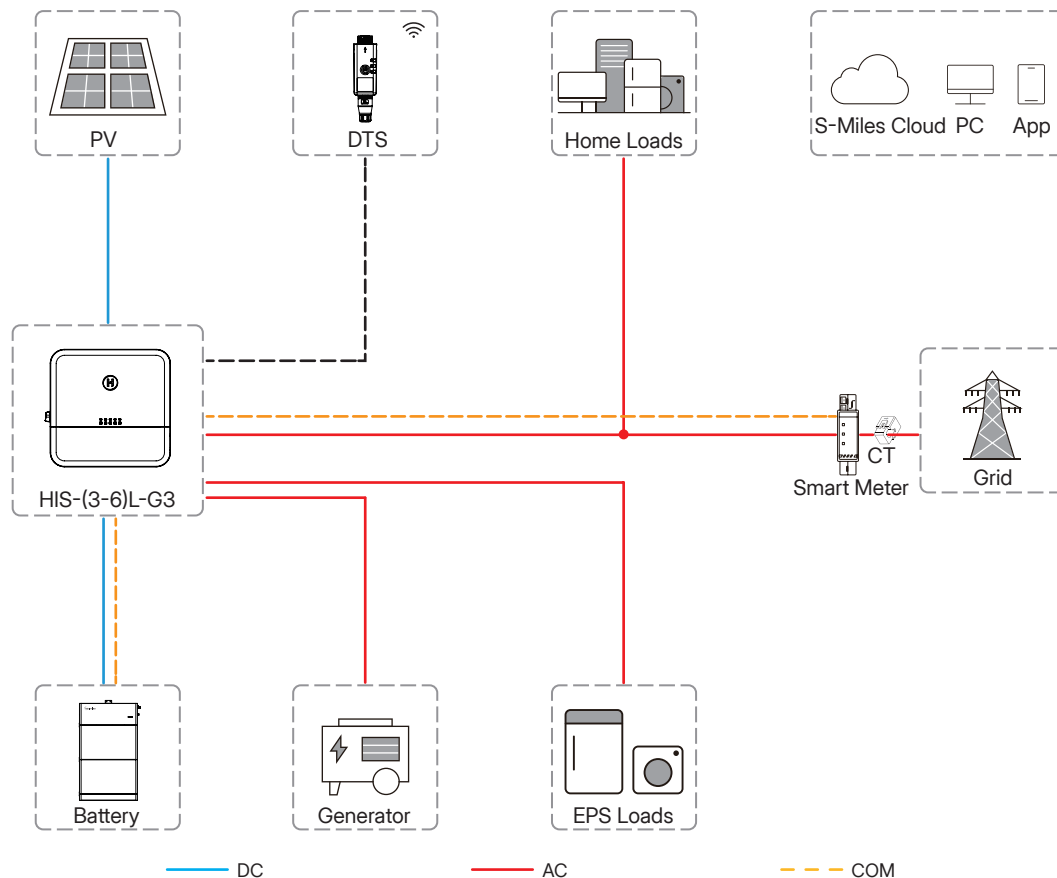

Figure 16-1 Generator System-Manual Mode

▷ Auto Mode

In this mode, users can control the system by establishing a dry contact connection between the inverter and the generator. It has multiple parameters for users to set so that the system can meet the requirements of different scenarios.

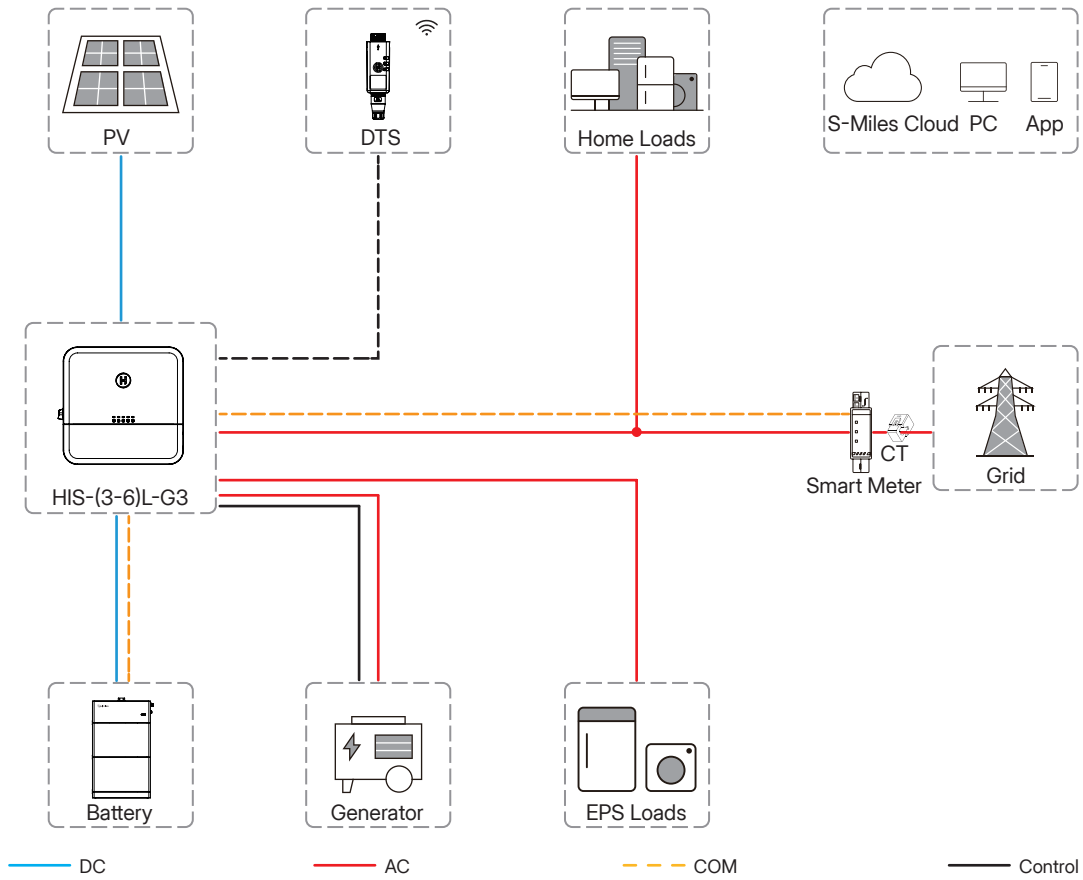
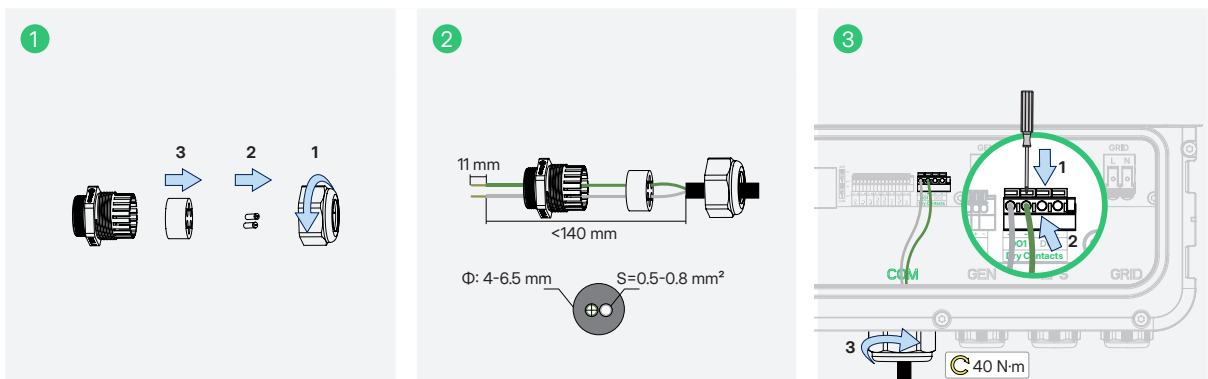

Figure 16-2 Generator System-Auto Mode

Communication Connection



Online Setting

Refer to [9 S-Miles Cloud](#) or [S-Miles Cloud User Manual \(App\)](#). Detailed parameters are shown as follows.

NOTE

Please set these values according to your actual needs and generator parameters.

A. Advanced Settings

- System Setting

Parameter	Description
GEN Port Mode	To ensure the normal operation of the generator, please select "Generator".

- Generator Setting

Parameter	Range
GEN Location	None/GenSide. To ensure the normal operation of the generator, please select "GenSide".
GEN Signal Setting	Manual or DI/DO. If the generator cannot be controlled by dry contact, please select "Manual". If the generator can be controlled by dry contact, please select "DI/DO".
Min. Run Time	5-60 min
Max. Run Time	6-10 hour
Protection Interval	5-60 min
Synchronize Time	1-20 min
Shutdown Delay	1-20 min
GEN Rated Power	0-20000 W
High Voltage Limit	0-280 V
Low Voltage Limit	0-180 V
High Frequency Limit	0-70 Hz
Low Frequency Limit	0-59 Hz
Max. GEN Charging Power	0-20000 W

B. System Settings > Dry Contact Settings > Generator Control

- Exercise Mode

The generator starts regularly during the preset period to ensure the operation of the generator.

Parameter	Description
Frequency	It allows the generator to start regularly at this frequency.
Start Time	It allows the generator to start regularly at this time.
Duration	The generator will stop running after this duration.

- Running Mode

This mode is the off-grid operation mode of the generator, including manual mode and auto mode.

▷ Manual Mode

The manual mode is used to turn on or turn off the generator manually.

▷ Auto Mode

The auto mode is used to turn on or turn off the generator according to the battery capacity. The auto mode only supports generators controlled by Dry Contact. Otherwise, please select the manual mode.

Parameter	Description
GEN Start SOC	In off-grid mode, start the generator when the battery capacity is lower than the safety SOC.
GEN Shutdown SOC	In generator mode, shut down the generator when the battery capacity is higher than the safety SOC.
Quiet Time	During the quiet time, the generator is disabled. If you set this time, it will affect the normal use of electricity.

- Battery Charge Time

Parameter	Description
Battery Charge Time	The generator will charge the battery during the preset period. Please choose the time period when the PV power is low to avoid wasting PV power.

17 Appendix 5: Application of EV Charger

EV Charger Function Introduction

The EV charger is used to charge electric vehicles. It should be installed in a fixed location and connected to the AC power supply. The EV charger can communicate with the inverter to realize intelligent control of the charging process.

System Diagram

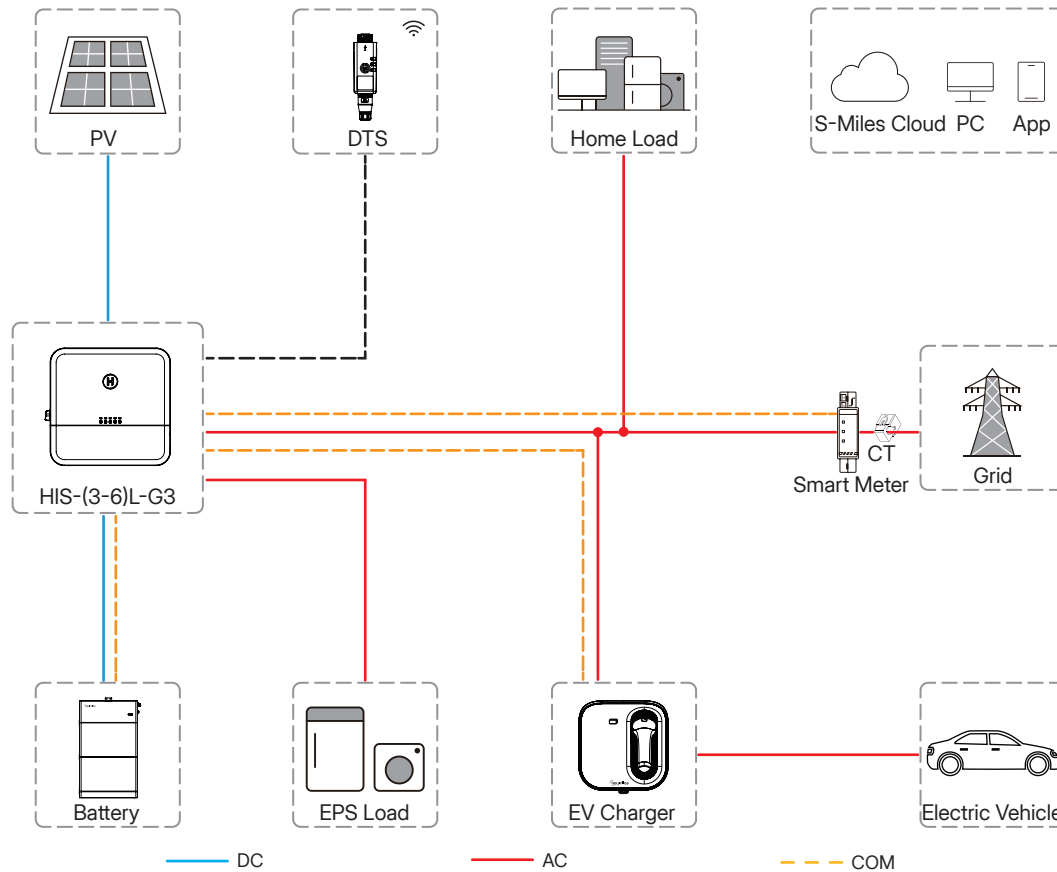

Figure 17-1 EV Charger System

Green Power Mode

The green power mode is to use the surplus PV power in preference to charge the electric vehicle.

Surplus PV power = PV power - Load consumption - ESS charging power.

To protect the electric vehicle, users need to set the value of Max Charging Power from Grid when enabling the green power mode. This is to ensure that the charger still can charge the electric vehicle when the PV power is not stable or the surplus PV power is less than the EV charger start power.

NOTE

- The minimum start power of Hoymiles single-phase EV charger is 1.4 kW.
- The minimum start power of Hoymiles three-phase EV charger is 4.2 kW.
- It is recommended that the set grid input power should be larger than the EV charger start power, otherwise, the EV charger may not start.

Communication Connection

Respectively connect the RS485A terminal and RS485B terminal of the EV charger to the RS485_1 (A) terminal and RS485_1 (B) terminal of HIS series inverter.

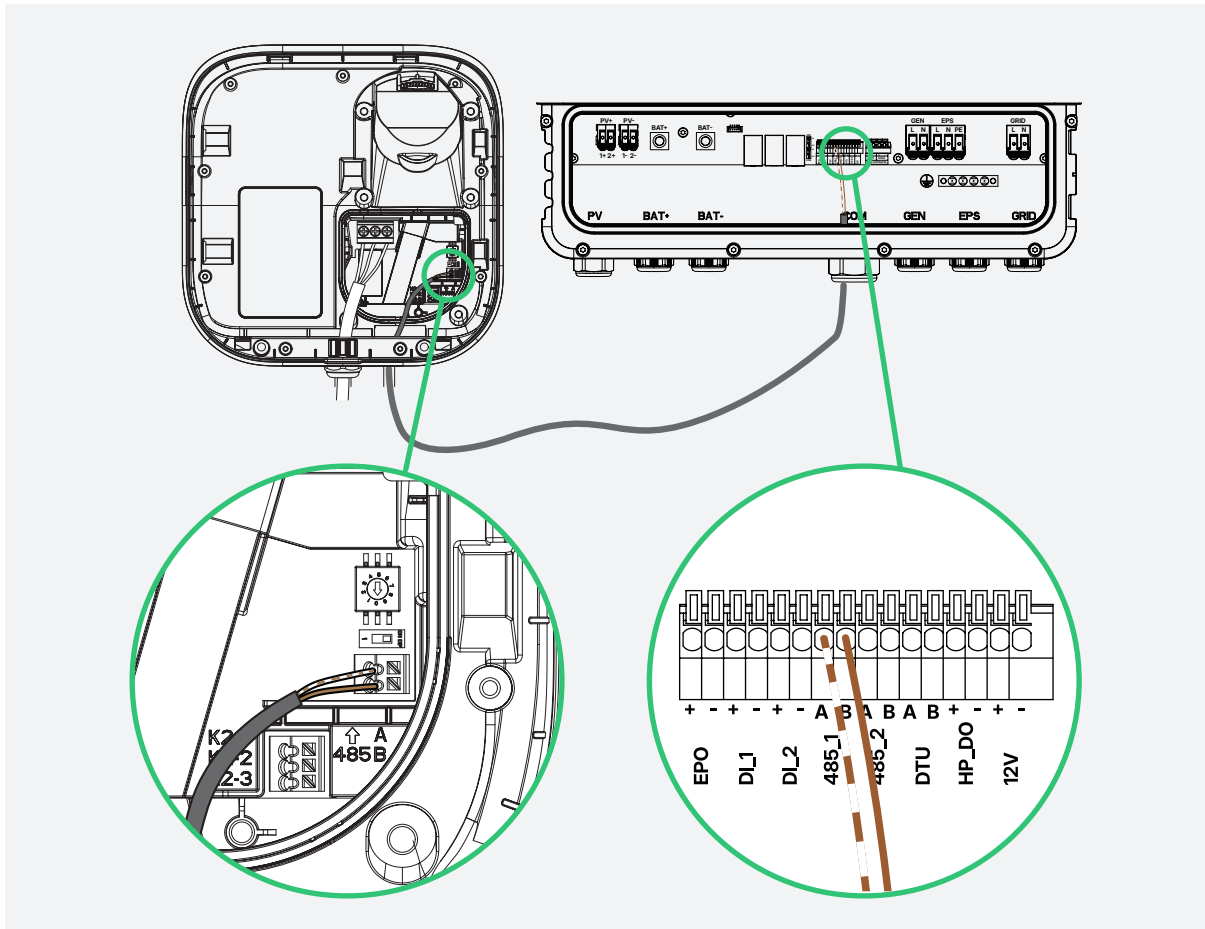

Figure 17-2 Communication Connection

Online Setting

Refer to [S-Miles Cloud User Manual \(App\)](#). Detailed parameters are shown as follows.

Parameter	Description
Charging Power Setting	The maximum charging power of the EV charger. VAS-7-G2: 7 kW (default value); 1.4 kW-7 kW (range) VAT-11-G2: 11 kW (default value); 4.2 kW-11 kW (range) VAT-22-G2: 22 kW (default value); 4.2 kW-22 kW (range)
Offline Charging Power	The EV charger will charge the electric vehicle at this power if there is a communication failure between the EV charger and the inverter.
Charging Mode	RFID Card / Free Charge

18 Appendix 6: Application of Heat Pump

Heat Pump Function Introduction

In many European countries, most households are equipped with heat pump systems (Heat Pump or Electric Modulating Heater). By adding heat pump control ports, it is possible to control the startup and the power usage of the heat pump through the inverter, thus achieving the goals of intelligent control and maximizing the utilization of PV energy.

System Diagram

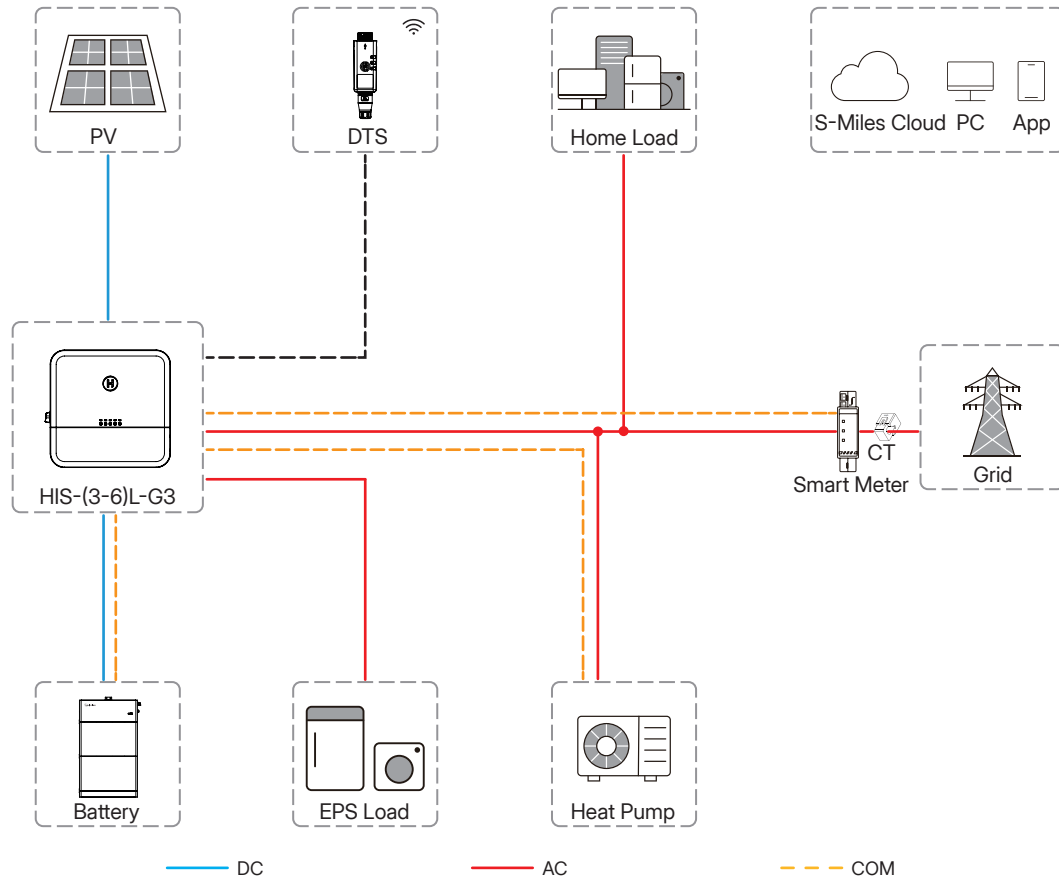

Figure 18-1 Heat Pump System

DO/SG Ready Heat Pump Connection

The surplus PV power can be converted into thermal storage when you have a DO/SG Ready heat pump.

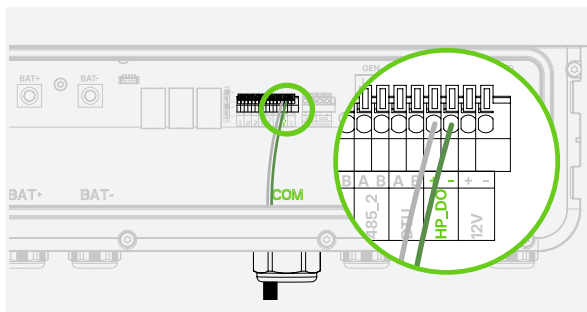

Figure 18-2 Dry Contact Control

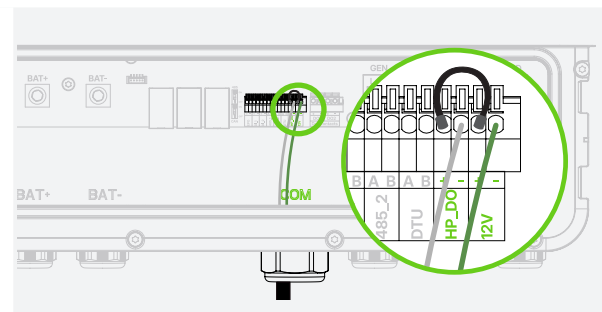

Figure 18-3 12 V @100 mA External Relay Control

NOTE

For the connection shown in Figure 18-3, select an appropriate external relay based on the type of SG Ready heat pump.

Online Setting

Refer to [9.3.5 Set Dry Contact Function](#) or [S-Miles Cloud User Manual \(App\)](#). Detailed parameters are shown as follows.

Parameter	Description
Start Power	When the start power reaches this value, the heat pump control mode is enabled.
Shutdown Power	When the shutdown power reaches this value, the heat pump control mode is disabled.
Battery Starting SOC (Optional)	When the battery SOC reaches this value, the heat pump control mode is enabled.
Battery Shutdown SOC	When the battery SOC reaches this value, the heat pump control mode is disabled.
Min. Single Runtime	When the single runtime reaches this value, the heat pump control mode is disabled.
Max. Single-day Runtime (Optional)	When the running time of the day reaches this value, the heat pump control mode is disabled.
Runtime Settings	Up to 4 operating periods can be set.

NOTE

- The shutdown conditions have a higher priority than the start conditions. When the start conditions are met, the shutdown conditions also need to be checked. If the shutdown conditions are also met, the heat pump cannot be started.
- The min. single runtime has the highest priority.
- In the off-grid mode, the battery starting SOC must be set.
- If there is no battery connected, only the start or shutdown power needs to be set.
- The interval between disabling and enabling the heat pump is not less than 10 minutes.



Hoymiles Power Electronics Inc.

 Floor 6, Building 5, 99 Housheng Road,
Gongshu District, Hangzhou 310015 P. R. China

 +86 571 2805 6101

 hoymiles.com

 service@hoymiles.com
support@hoymiles.com

